

**DVI-D INTERFACE CONTROLLER
FOR 2560x1600 resolution TFT PANEL**

Model: DVI-2560

Part number : 417130020-3

INSTRUCTIONS

CONTENTS

Page: **2. Introduction, How to Proceed, Usage Note, Disclaimer**
2. System design – Diagram of a suggested system
3. Assembly notes – Important information about system elements
5. Connection & Operation – How to use the controller
7. Connectors, pinouts & jumpers – Essential connection information
11. Controller dimensions
12. Application notes
13. Troubleshooting
14. Specifications
15. Appendix I – Graphic Mode Support Table
16. Warranty, Caution & Limitation of Liability, Trademarks
17. Contact details

It is essential that these instructions are read and understood before connecting or powering up this controller.

Introduction

Designed for 2560x1600 LCD monitor applications, the DVI-2560 controller provides easy to use interface controller for:

- **TFT (active matrix) LCDs with TMDS interface of 2560x1600 resolution**
Panel model support :
 1. LG LM300W01-A3
 2. Samsung LTB300M1-P01
 3. Samsung LTM300M1-P01
- **DVI-D input signals of WQXGA (2560x1600 60Hz) standard**

HOW TO PROCEED

- Ensure you have all parts & that they are correct, refer to:
 - Connection diagram (separate document for each panel)
 - Connector reference (in following section)
 - Assembly notes
- Check controller switch & jumper settings (errors may damage the panel)
- Prepare the PC
- Connect the parts
- Understand the operation and functions (in following section)

IMPORTANT USAGE NOTE

This product is for use by system developers and integrators, the manufacturer accepts no liability for damage or injury caused by the use of this product. It is the responsibility of the developer, integrators or other user of this product to:

- Ensure that all necessary and appropriate safety measures are taken.
- Obtain suitable regulatory approvals as may be required.
- Check power settings to all component parts before connection.
- Understand the operation and connectivity requirements of this controller.

DISCLAIMER

There is no implied or expressed warranty regarding this material.

SYSTEM DESIGN

A typical LCD based display system utilising this controller is likely to comprise the following:

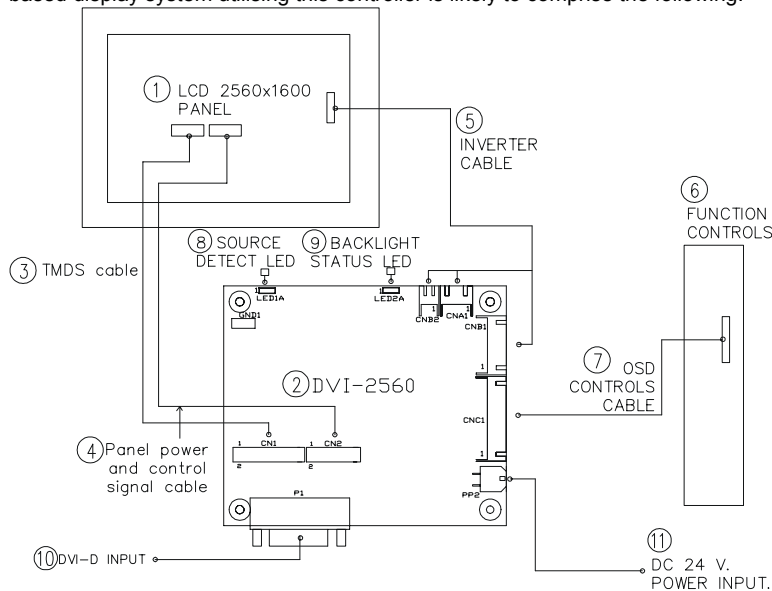

Summary:

1. LCD 2560x1600 resolution panel
2. LCD controller card, DVI-2560
3. TMDS cable
4. Panel power and control signal cable
5. Inverter cable
6. Function controls
7. Function controls cable
8. Source detect LED
9. Backlight status LED
10. DVI-D input
11. Power input (24VDC)

Digital View offers a range of accessories such as listed above, to make up complete display solution.

ASSEMBLY NOTES

This controller is designed for monitor and custom display projects using 2560x1600 resolution TFT panels with WQXGA (2560x1600 60Hz) signal input. The following provides some guidelines for installation and preparation of a finished display solution.

Preparation: Before proceeding it is important to familiarize yourself with the parts making up the system and the various connectors, mounting holes and general layout of the controller. As much as possible connectors have been labeled. Guides to connectors and mounting holes are shown in the following relevant sections.

1. **LCD Panel:** This controller is designed for typical TMDS interface TFT panels with panel voltage 18V. Due to the variation between manufacturers of signal timing and other panel characteristics factory setup and confirmation should be obtained before connecting to a panel. **(NOTE: Check panel power jumper settings before connection)**
2. **Controller card:** Handle the controller card with care as static charge may damage electronic components.
3. **TMDS signal cable :** In order to provide a clean signal it is recommended that TMDS signal cables are no longer than 46cm (18 inches). If loose wire cabling is utilized these can be made into a harness with cable ties. Care should be taken when placing the cables to avoid signal interference. Additionally it may be necessary in some systems to add ferrite cores to the cables to minimize signal noise.
4. **Panel power and control signal cable :** This cable provides panel power and control signal for the panel. If loose wire cabling is utilized these can be made into a harness with cable ties. Care should be taken when placing the cables to avoid signal interference. Additionally it may be necessary in some systems to add ferrite cores to the cables to minimize signal noise.
5. **Inverter Cables:** Different inverter models require different cables and different pin assignment. Make sure correct cable pin out to match the inverter. Using wrong cable pin out may damage the inverter.
6. **Function Controls:** The following section discusses the controls required and the section on connectors provides the detail. The controls are minimal: On/Off, Backlight Brightness (depends on inverter).
7. **Function controls cable:** The cables to the function switches should be of suitable quality and length so that impedance does not affect performance. Generally lengths up to 1 metre (3 feet) should be acceptable.
8. **Source detect LED (LED1A) :**
This LED shows the input source detected status. It will give Green color for signal detected and Red color for signal not detected.
9. **Backlight status LED (LED2A) :**
This LED shows the backlight status. It will give Green color indicated for normal backlight status and Red color indicated for not normal backlight status.
10. **DVI-D Input Cable :** Plug the DVI cable to the connector P1 on the controller board
11. **Power Input:** 24V DC is required, this should be a regulated supply. Although the controller provides power regulation for the LCD power this does not relate to the power supplied to the backlight inverter. If an unregulated power supply is provided to an inverter any fluctuations in power may affect operation, performance and lifetime of the inverter and or backlight tubes.
 - **Power Safety:** Note that although only 24VDC is supplied as 'power-in' a backlight inverter for panel backlighting produces significantly higher voltages (the inverter does not connect to the ground plane). We strongly advise appropriate insulation for all circuitry.
 - **EMI:** Shielding will be required for passing certain regulatory emissions tests. Also the choice of external Controller to PC signal cable can affect the result.
 - **Ground:** The various PCB mounting holes are connected to the ground plane.
 - **Servicing:** The board is not user serviceable or repairable. Warranty does not cover user error in connecting up to the controller and is invalidated by unauthorized modification or repairs.
 - **Controller Mounting:** It is recommended that a clearance of at least 10mm is provided above and 5mm below the controller when mounted. Additionally consideration should be given to:
 - Electrical insulation.
 - Grounding.
 - EMI shielding.
 - Cable management. Note: It is important to keep panel signal cables apart from the inverter & backlight cables to prevent signal interference.
 - Heat & Ventilation: Heat generated from other sources, for example the backlight of a very high brightness panel may generate significant heat which could adversely affect the controller.
 - Other issues that may affect safety or performance.

- **PC Graphics Output:** A few guidelines:
 - Signal quality is very important, if there is noise or instability in the PC graphics output this may result in visible noise on the display.
 - Refer to graphics modes table in specifications section for supported modes.

IMPORTANT: Please read the Application Notes section for more information.

CONNECTION & OPERATION

CAUTION: Never connect or disconnect parts of the display system when the system is powered up as this may cause serious damage.

CONNECTION

Connection and usage is quite straight forward (it is useful to have the relevant connection diagram available at this time):

1. **LCD panel** : This controller only support 18V 2560x1600 resolution panel model – LG LM300W01-A3, Samsung LTB300M1-P01 and Samsung LTM300M1-P01.
2. **TMDS panel cable connection** : Plug the TMDS signal cable direct to CN1. Insert the panel end of the cable to the LCD panel connector.
3. **Panel power and control signal connection** : Plug the panel power and control signal cable direct to CN2. Insert the panel end of the cable to the LCD panel connector.
4. **Inverter & Controller:** Plug the inverter cable to CNA1, CNB1 and CNB2. Plug another end to the connector on the panel built-in inverter.
5. **Function switch & Controller:** Plug the OSD switch mount cable to CNC1 on the controller board and another to the OSD switch mount.
6. **LED & Controller:** Plug in a 3-way with dual colour LED to connector LED1A & LED2A on the controller board.
7. **Jumpers** : Check all jumpers are set correctly. Details referring the connection diagram at <http://www.digitalview.com/controllers/csg.php>
8. **Jumpers & Inverter & Panel voltage:** Particularly pay attention to the settings of JB1, JB2, JB3. JB1 is used for setting the backlight brightness control voltage range on specific inverter. JB2 & JB3 are used for inverter control (read inverter specification and information on the jumper table to define the correct settings). This controller is now always to default output 18V panel power.
8. **DVI-D cable** : Plug the DVI cable to the connector P1 on the controller board.
9. **Power supply & Controller:** Plug the DC 24V power in to the connector PP2. You can consider to use DigitalView mating power cable P/N 426013700-3, 160mm.
10. **Power on:** Switch on the controller board and panel by using the OSD switch mount.

CAUTION: Never connect or disconnect parts of the display system when the system is powered up as this may cause serious damage.

General:

- If you are using supplied cables & accessories, ensure they are correct for the model of panel and controller.
- If you are making your own cables & connectors refer carefully to both the panel & inverter specifications and the section in this manual, “Connectors, Pinouts & Jumpers” to ensure the correct pin to pin wiring.

PC SETTINGS

The controller has been designed to support DVI 2560x1600 60Hz mode coming from graphics display card only.

OPERATION

The controller can allow you to switch on/off the board and controlling the backlight brightness via OSD switch mount.

LCD DISPLAY SYSTEM SETTINGS

NOTE: By way of explanation the following refers to a set of sample buttons on the OSD switch mount that may be obtained as an option

Controls	Analog VR type	Digital type
On/Off – turns controller board power on	VR toggle switch	On/Off button
Brightness – controls backlight brightness	Rotary VR	Brightness +/- buttons

** “Menu”, “SEL UP”, “SEL DN”, “+”, “-” keys are all no function.

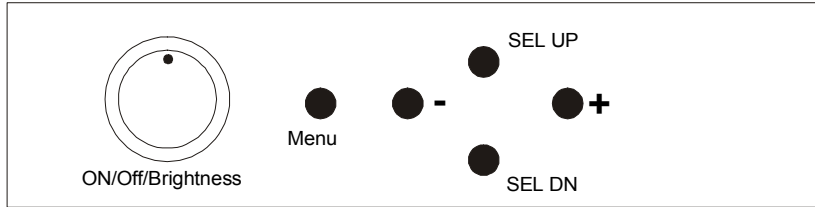

Analog VR type

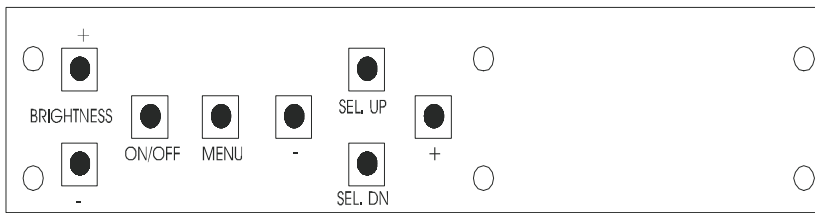

Digital type

CONNECTORS, PINOUTS & JUMPERS

The various connectors are:

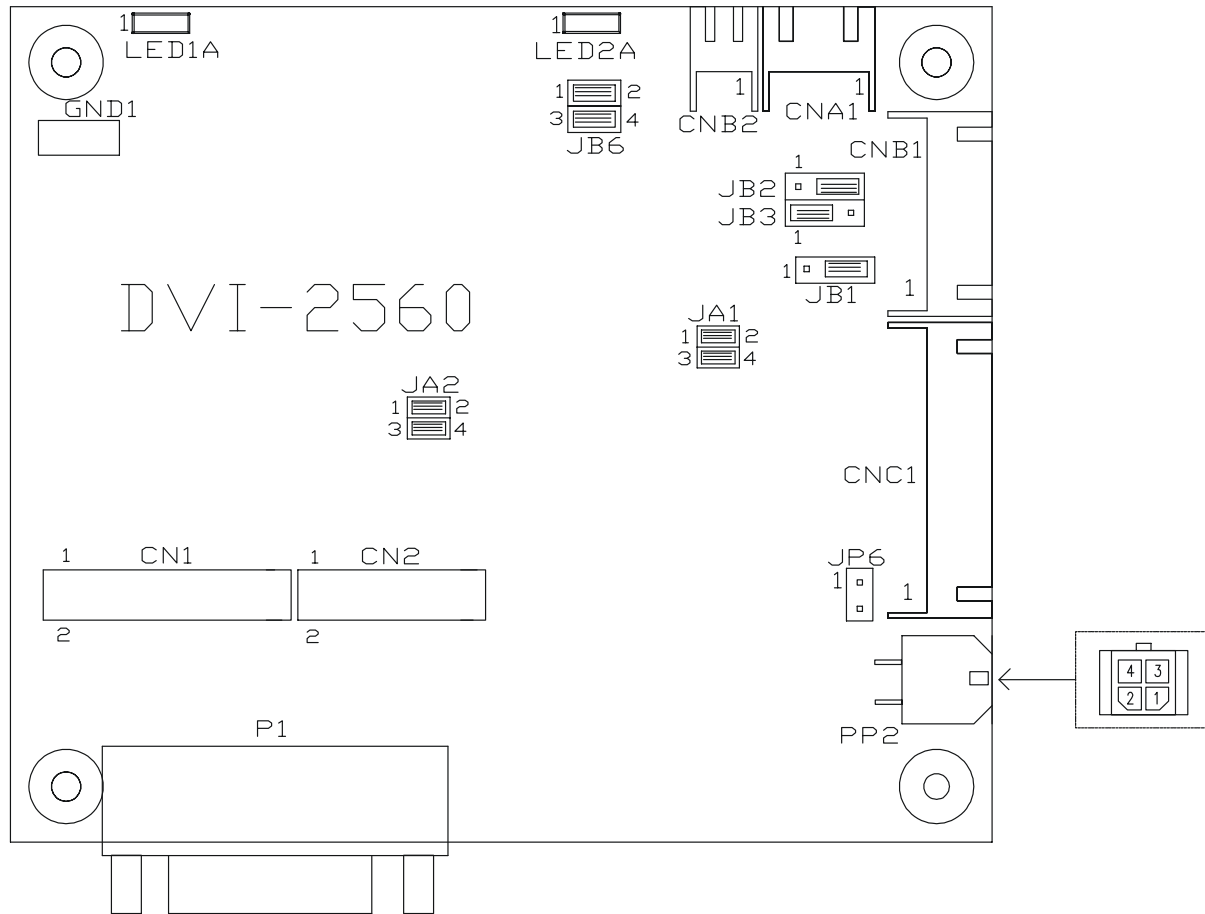

Summary: Connectors

Ref	Purpose	Description
CN1	TMDS panel signal	Hirose 30-pin, DF13-30DP-1.25 (Mating type : DF13-30DS-1.25C)
CN2	Panel power and control signal	Hirose 20-pin, DF13-20DP-1.25 (Mating type : DF13-20DS-1.25C)
CNA1	Auxiliary power output	JST 4-way, B4B-XH-A (Mating type : XHP-4)
CNB1	Backlight inverter	JST 8-way, B8B-XH-A (Mating type : XHP-8)
CNB2	Backlight inverter	JST 2-way, B2B-XH-A (Mating type : XHP-2)
CNC1	Function controls	JST 12-way, B12B-XH-A (Mating type : XHP-12)
LED1A	Source detected LED	Header pin 3x1
LED2A	Backlight status LED	Header pin 3x1
P1	DVI-D signal input	DVI-D connector
PP2	Power input	Molex 43045-0400 compatible (Matching connector type : Molex 43025-0400 compatible) (Matching power cable : P/N 426013700-3)

Summary: Jumpers setting

Ref	Purpose	Note
JA1	On board +5V power enable	1-2 & 3-4 closed, factory set, do not remove
JA2	Panel power	1-2 & 3-4 closed, factory set, do not remove
JB1	Backlight brightness control voltage range	1-2 closed = 3.3V max 2-3 closed = 2.8V max
JB2	Backlight inverter on/off control – signal level	1-2 = On/Off control signal 'High' = +5V 2-3 = On/Off control signal 'High' = +3.3V Open = On/Off control signal 'High' = Open collector CAUTION: Incorrect setting can damage inverter.
JB3	Backlight inverter on/off control – polarity	1-2 = control signal 'high' = CCFT ON 2-3 = control signal 'low' = CCFT ON
JB6	Backlight status	1-2 & 3-4 closed = Backlight status Low = Normal 1-3 & 2-4 closed = Backlight status High = Normal Open = Backlight status not used
JP6	Input power control	Short = External switch control Open = Switch mount control

LED1A – Source detected LED status :

Source detected state	LED color
Detected	GREEN
Not detected	RED

LED2A – Backlight status LED status :

Backlight status state	LED color
Normal	GREEN
Not normal	RED

CN1 – Panel connector: HIROSE DF13-30DP-1.25 (Matching type : HIROSE DF13-30DS-1.25C)

PIN	SYMBOL	DESCRIPTION
1	GND	Ground
2	GND	Ground
3	RX0+	TMDS positive differential output (Channel 0)
4	RX0-	TMDS negative differential output (Channel 0)
5	GND	Ground
6	GND	Ground
7	RX1+	TMDS positive differential output (Channel 1)
8	RX1-	TMDS negative differential output (Channel 1)
9	GND	Ground
10	GND	Ground
11	RX2+	TMDS positive differential output (Channel 2)
12	RX2-	TMDS negative differential output (Channel 2)
13	GND	Ground
14	GND	Ground
15	RX3+	TMDS positive differential output (Channel 3)
16	RX3-	TMDS negative differential output (Channel 3)
17	GND	Ground
18	GND	Ground
19	RX4+	TMDS positive differential output (Channel 4)
20	RX4-	TMDS negative differential output (Channel 4)
21	GND	Ground
22	GND	Ground
23	RX5+	TMDS positive differential output (Channel 5)
24	RX5-	TMDS negative differential output (Channel 5)
25	GND	Ground
26	GND	Ground
27	RXC+	TMDS positive differential output (Channel C)
28	RXC-	TMDS negative differential output (Channel C)
29	GND	Ground
30	GND	Ground

CN2 – Panel connector: HIROSE DF13-20DP-1.25 (Matching type : HIROSE DF13-20DS-1.25C)

PIN	SYMBOL	DESCRIPTION
1	PHSYNC	H-sync from panel
2	PVSYNC	V-sync from panel
3	LCM_ON	Panel power on signal
4	NC	No connection
5	GND	Ground
6	GND	Ground
7	VLCD	Panel power
8	GND	Ground
9	VLCD	Panel power
10	VLCD	Panel power
11	VLCD	Panel power
12	VLCD	Panel power
13	GND	Ground
14	GND	Ground
15	GND	Ground
16	NC	No connection
17	NC	No connection
18	NC	No connection
19	NC	No connection
20	NC	No connection

CNA1 - Auxiliary power output: JST B4B-XH-A (Matching type : XHP-4)

PIN	SYMBOL	DESCRIPTION
1	24VA	+24V DC, 2A max
2	GND	Ground
3	GND	Ground
4	5V	+5V DC, 500mA max

CNB1 – Backlight inverter connector: JST B5B-XH-A (Matching type : XHP-5)

PIN	SYMBOL	DESCRIPTION
1	24VA	Backlight power supply, +24VDC
2	24VA	Backlight power supply, +24VDC
3	GND	Ground
4	GND	Ground
5	24VA	Backlight power supply, +24VDC
6	BLCTRL	Backlight On/Off control signal (refer to JB2 & JB3)
7	BVR_WIP	Backlight brightness VR pin WIP
8	BVR_A	Backlight brightness VR pin A

CNB2 - Auxiliary power output: JST B2B-XH-A (Matching type : XHP-2)

PIN	SYMBOL	DESCRIPTION
1	BL_STATUS	Backlight status
2	GND	Ground

CNC1 – Control switch, JST B12B-XH-A

PIN	SYMBOL	DESCRIPTION
1	PSWIN	Power button A
2	SW_ON	Power button B
3	BVR_A	Backlight Brightness VR pin A
4	BVR_WIP	Backlight Brightness R pin WIP
5	BVR_B	Backlight Brightness VR pin B (470 ohm resistor to +5V Vcc)
6	GND	Ground
7	NC	No connection
8	NC	No connection
9	NC	No connection
10	NC	No connection
11	NC	No connection
12	NC	No connection

LED1A – Source detected LED, Header pin 3x1

PIN	DESCRIPTION
1	Red LED pin (anode)
2	LED pin common (cathode)
3	Green LED pin (anode)

LED2A – Backlight status LED, Header pin 3x1

PIN	DESCRIPTION
1	Red LED pin (anode)
2	LED pin common (cathode)
3	Green LED pin (anode)

P1 – DVI-D input

PIN	SYMBOL	DESCRIPTION
1	/RX2	TMDS Data 2-
2	RX2	TMDS Data 2+
3	GND	Digital Ground
4	NC	No connection
5	NC	No connection
6	DVI_DDC_CLK	DDC Clock
7	DVI_DDC_DAT	DDC Data
8	DVI_VS_IN	Analog vertical Sync
9	/RX1	TMDS Data 1-
10	RX1	TMDS Data 1+
11	GND	Digital Ground
12	NC	No connection
13	NC	No connection
14	DVI_DDC_5V	+5V power supply for DDC (optional)
15	GND	Ground (+5, Analog H/V Sync)
16	NC	No connection
17	/RX0	TMDS Data 0-
18	RX0	TMDS Data 0+
19	GND	Digital Ground
20	NC	No connection
21	NC	No connection
22	GND	Digital Ground
23	RXC	TMDS Clock+
24	/RXC	TMDS Clock-
25	NC	No connection
26	NC	No connection

PP2 - 24VDC power supply input (Matching type : Molex 43025-0400 compatible)

PIN	DESCRIPTION
1	+24VDC
2	Ground
3	+24VDC
4	Ground

CONTROLLER DIMENSIONS

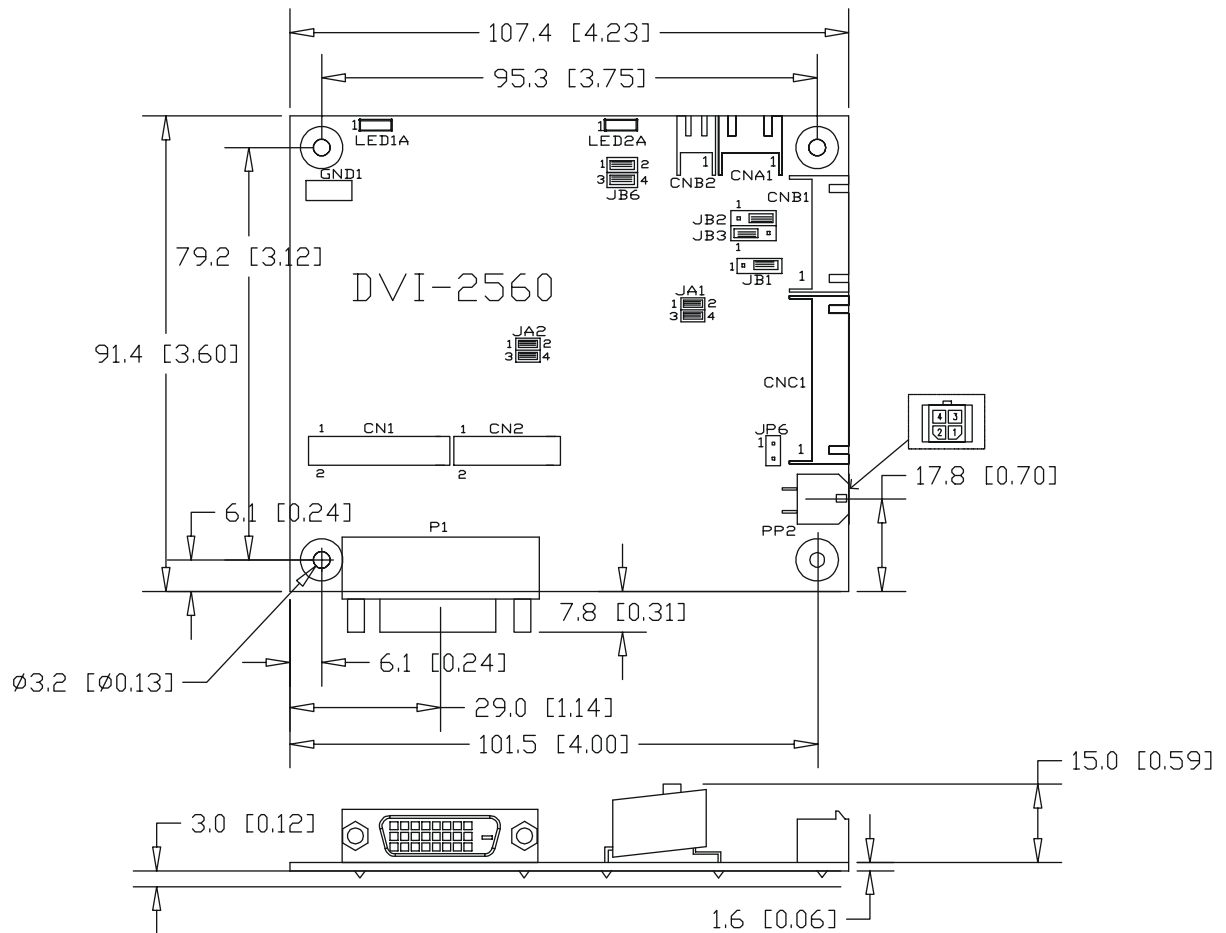

The maximum thickness of the controller is 19.6mm (measured from bottom of PCB to top of components, including any underside components & leads). We recommend clearances of:

- 5mm from bottom of PCB - if mounting on a metal plate we also recommend a layer of suitable insulation material is added to the mounting plate surface.
- 10mm above the components
- 3~5mm around the edges

Any of the holes shown above can be used for mounting the PCB, they are 3.2mm in diameter.

CAUTION: Ensure adequate insulation is provided for all areas of the PCB with special attention to high voltage parts such as the inverter.

APPLICATION NOTES

USING THE CONTROLLER WITHOUT BUTTONS ATTACHED

This is very straightforward by following the steps below :

- Use a jumper to close JP6 jumper, this will fix the board On.
- Refer to inverter specifications for details as to fixing brightness to a desired level, this may require a resistor, an open circuit or closed circuit depending on inverter.

INVERTER CONNECTION

There are potentially 3 issues to consider with inverter connection:

- Power
- Enable
- Brightness

Please read the following sections for a guide to these issues.

Inverter Power: As per the table for CNB1 pin 3,4 are ground and pin 1,2,5 provides 24VDC. This should be matched with the inverter specification: see table.

CNB1

PIN	DESCRIPTION
1	Backlight power supply, +24VDC
2	Backlight power supply, +24VDC
3	Ground
4	Ground
5	Backlight power supply, +24VDC

Enable: This is a pin provided on some inverters for On/Off function and is used by this panel controller for VESA DPMS compliance. If the inverter does not have an enable pin or the enable pin is not used then DPMS will not be operational. Pin 6 should be matched to the inverters specification for the 'enable' or 'disable' pin.

CNB1

PIN	DESCRIPTION
6	Enable

Further, jumpers JB2 & JB3 should be set to match the inverters specification for the enable pin power and High or Low setting: see table.

Ref	Purpose	Note
JB2	Inverter enable voltage	1-2 H = 5V, 2-3 H = 3.3V, OPEN H = open collector
JB3	Inverter control	1-2 H = On, 2-3 L = On

Brightness: There are various methods for brightness control and it is important to consider the specifications for the inverter to be used. Generally the situation is:

- Brightness can controlled by using a resistor or VR (Variable Resistor).
- No adjustment of brightness is possible.

CNB1 pins 4 & 5 are available for connecting to an inverter or circuit where VR control is supported.

CNB1

PIN	DESCRIPTION
7	VR WIP
8	VR A

This can then be matched with function controls (OSD switch mount) pins 3 & 4: see cable design below .

TROUBLESHOOTING

General

A general guide to troubleshooting a flat panel display system it is worth considering the system as separate elements, such as:

- Controller (jumpers, PC settings)
- Panel (controller, cabling, connection, panel, PC settings)
- Backlight (inverter, cabling, backlight tubes)
- Cabling
- Computer system (display settings, operating system)

Through step by step cross checking with instruction manuals and a process of elimination to isolate the problem it is usually possible to clearly identify the problem area.

No image:

- If the panel backlight is not working it may still be possible to just see some image on the display.
- A lack of image is most likely to be caused by incorrect connection, lack of power, failure to provide a signal or incorrect graphic card settings.

Image appearance:

- A faulty panel can have blank lines, failed sections, flickering or flashing display
- Incorrect graphics card refresh rate, resolution or interlaced mode will probably cause the image to be the wrong size, to scroll, flicker badly or possibly even no image.
- Incorrect jumper settings on the controller may cause everything from total failure to incorrect image. CAUTION: Do not set the panel power input incorrectly.
- Sparkling on the display: faulty panel signal cable.

Backlight:

Items to check include: Power input, Controls, Inverter and Tubes generally in this order.

If half the screen is dimmer than the other half:

- Check cabling for the inverter.
- For a specific backlight tube check the AC pins orientation (CAUTION: Never reverse any DC power pins).

Also:

- If adjusting brightness control has no effect the chances are that the VR rating or method of adjusting brightness is not compatible or correctly connected to the inverter.
- If system does not power down when there is a loss of signal

Continued failure:

If unit after unit keeps failing consider and investigate whether you are short circuiting the equipment or doing something else seriously wrong.

Generally after common sense issues have been resolved we recommend step by step substitution of known working parts to isolate the problem.

SPECIFICATIONS

Panel compatibility	2560x1600 resolution TFT TMDS 18V LCD's panel support.
No. of colours	Up to 3 x 8 bit providing 16.7 million colours.
Vertical refresh rate	WQXGA (2560x1600) resolution up at 60Hz.
Graphics formats	2560x1600 60Hz signal
Standard input at source	- DVI-D
Controls available	- On/Off - Brightness (inverter)
VESA DPMS implementation	Yes
Plug & Play	VESA DDC 1, 2/b compatible
Voltage output for LCD	+18V only
Input voltage	24VDC
Controller power consumption	Approx 1.5W (controller logic only, no panel and inverter are involved)
Controller dimensions	107mm x 92mm x 19.6mm
Storage temperature limits	-40°C to +70°C
Operating temperature limits	0°C to +60°C

NOTES

Please note the following:

- For specific panel setup a sample of an LCD may be required (this will be returned) and a copy of the full technical specifications for the panel from the manufacturer.
- Relayout and custom development services are available.

Appendix I – Graphic Mode Support Table

Mode	Resolution	Interface
WQXGA	2560x1600 60Hz	DVI-D

WARRANTY

The products are warranted against defects in workmanship and material for a period of three (3) year from the date of purchase provided no modifications are made to it and it is operated under normal conditions and in compliance with the instruction manual.

The warranty does not apply to:

- Product that has been installed incorrectly, this specifically includes but is not limited to cases where electrical short circuit is caused.
- Product that has been altered or repaired except by the manufacturer (or with the manufacturer's consent).
- Product that has subjected to misuse, accidents, abuse, negligence or unusual stress whether physical or electrical.
- Ordinary wear and tear.

Except for the above express warranties, the manufacturer disclaims all warranties on products furnished hereunder, including all implied warranties of merchantability and fitness for a particular application or purpose. The stated express warranties are in lieu of all obligations or liabilities on the part of the manufacturer for damages, including but not limited to special, indirect consequential damages arising out of or in connection with the use of or performance of the products.

CAUTION

Whilst care has been taken to provide as much detail as possible for use of this product it cannot be relied upon as an exhaustive source of information. This product is for use by suitably qualified persons who understand the nature of the work they are doing and are able to take suitable precautions and design and produce a product that is safe and meets regulatory requirements.

LIMITATION OF LIABILITY

The manufacturer's liability for damages to customer or others resulting from the use of any product supplied hereunder shall in no event exceed the purchase price of said product.

TRADEMARKS

The following are trademarks of Digital View Ltd:

- Digital View
- DVI-2560

CONTACT DETAILS

Digital View has offices in Asia, Europe and USA also an internet site:

ASIA

Digital View Ltd
19 th Floor Tai Tung Building
8 Fleming Road, Wanchai
Hong Kong

Tel: (852) 2861 3615

Fax: (852) 2520 2987

Sales: hksales@digitalview.com

EUROPE

Digital View Ltd.
6 Marylebone Passage,
London, W1W 8EX
UK

Tel: +44-(0)20-7631-2150

Fax: +44-(0)20-7631-2156

Sales: uksales@digitalview.com

USA

Digital View Inc.
18440 Technology Drive
Building 130
Morgan Hill,
California, 95037
USA

Tel: (1) 408-782 7773

Fax: (1) 408-782 7883

Sales: ussales@digitalview.com

WEBSITE

www.digitalview.com

Specifications subject to change without notice

2nd issue: 4 May, 2007 (DVI-2560.doc)

© Digital View Ltd 2007