

Rev1	09.18.02	First release
Rev2	11.12.03	Drawing update
Rev3	07.01.04	Revise Label position
Rev4	01.17.05	Modify Inspector Label

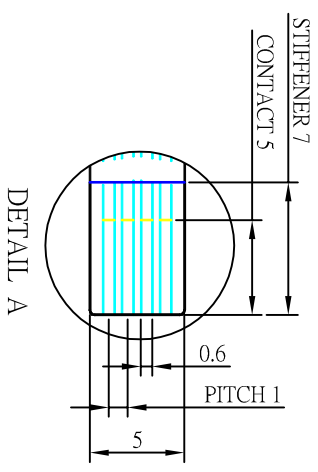
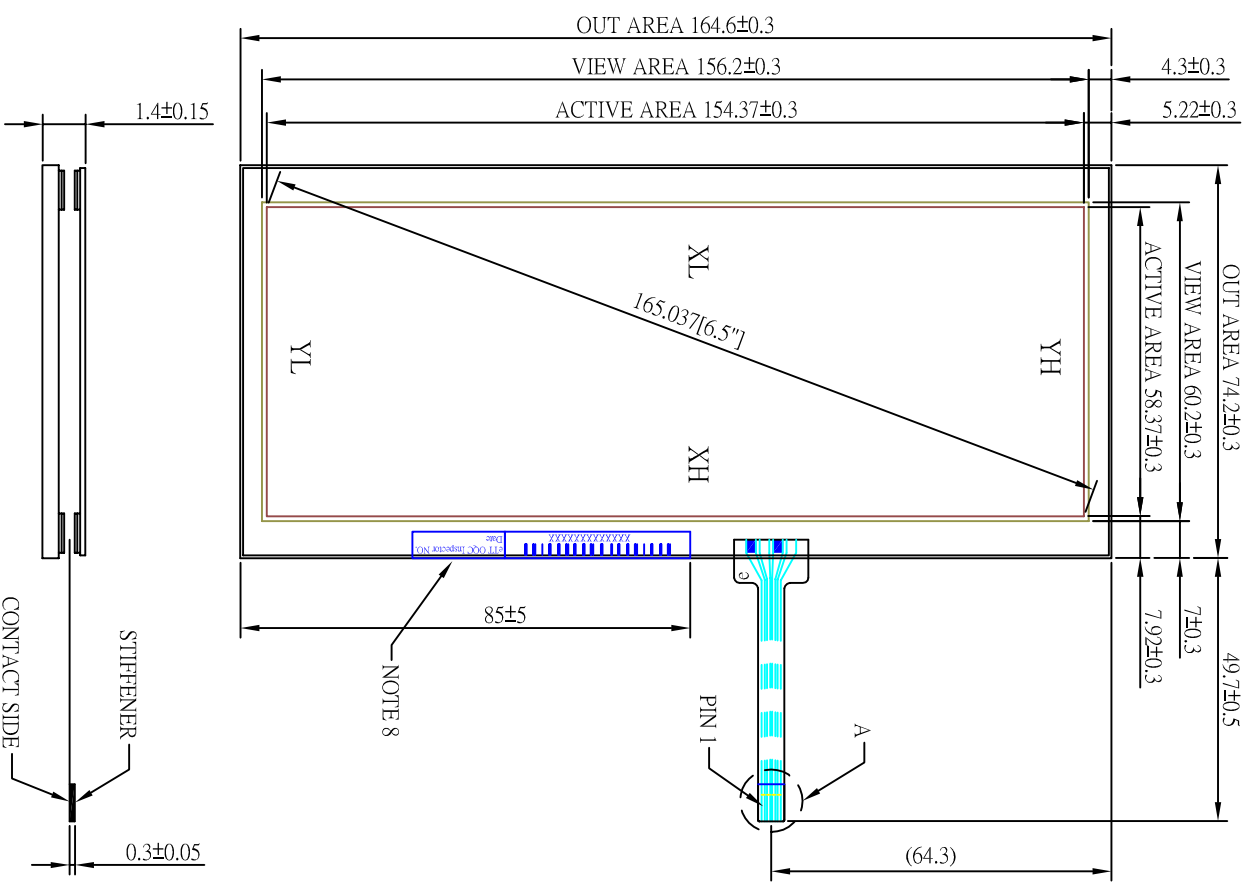

PIN OUT	1	2	3	4
YL	XH	YH	XL	

- NOTES:
1. TOPSHEET FINISH POLISHED
  2. GLASS THICKNESS 1.1mm
  3. FLEXTAIL DO NOT BEND TO LESS THAN 3.175mm RADIUS
  4. TAIL ACCEPTS 1mm PITCH ZIF CONN
  5. OVERALL SENSOR THICKNESS 1.4±0.15mm
  6. SENSOR INPUT PEN/PINGER
  7. TOPSHEET SET 0.5mm IN FROM GLASS EDGE ALL AROUND
  8. INSPECTOR LABEL, FAR SIDE. LABEL MUST BE OUTSIDE CVB.

THIRD ANGLE PROJECTION	Dimensions	
Drawn by Kawa Huang	Scale FREE	
Checked by	Release Date 01.17.05	
		Drawing Number S4-1064003FP