

### Introduction

CCFL inverter BI224 operates the VHB backlights in Landmark 15" to 17" sunlight readable LCD modules. The inverter has an on-board pulse width modulation (PWM) dimming circuit to provide an extremely wide luminance adjustment range. Over the entire dimming range, there is no noticeable lamp flickering and the uniformity of the backlight is well maintained. When using the BI224 with Landmark sunlight readable LCD modules, it is not necessary to synchronize the PWM circuit to the vertical sync signal of the LCD.

The BI224 inverter requires a 12V DC input. It can drive up to 12 CCFLs for a maximum lamp power of 42 Watts. In addition, the inverter has a regulated +5V output which serves as a voltage source for the dimming control circuit.

### Absolute Maximum Rating

Parameters	Min.	Max.	Units
Inverter Input Voltage (Vin)	11.0	13.0	Vdc
Operating Temperature Range	0	50	°C
Storage Temperature Range	-20	80	°C

## Electrical Characteristics

Parameters	Min.	Typ.	Max.	Units	Conditions
Input Voltage (Vin)	11.5	12	12.5	Vdc	
Input Current (I) BI224 with 15" LCD		4.0		Adc	Vin = 12V, Vd = 5V
Lamp Starting Voltage (Vst)		1,300		Vrms	Vin = 12V, Vd = 5V
Frequency (f)	56	60	64	KHz	
ON/OFF Control - OFF		0	0.2	Vdc	
- ON	4.8	5		V dc	
Dimming Voltage (Vd) Duty Cycle 100%		4.9	5	Vdc	Max. brightness
Duty Cycle 0%	≤0.54	≤0.56	≤0.58	Vdc	Zero brightness
+5V Output (+5VOUT)	4.85	5	5.25	Vdc	11.5 < Vin < 12.5V
+5V Output Source Current			5	mA	

**BI224 Inverter Typical Dimming Range  
with Landmark Sunlight Readable LCD Modules**

Landmark LCD Module Models	LCD Module Size	LCD Screen Luminance Range		Dimming Ratio
		Minimum	Maximum	
LM117C-150XA-03	15"	9 Cd/m <sup>2</sup>	1800 Cd/m <sup>2</sup>	200:1
LM126-150XH-T01	15"	7	1400	200:1
LM128-170E4-131	17"	3.8	750	200 :1

## Connector Pin Assignments

Input Connector CN1 (Molex 22-23-2071)		Output Connector CN2 & CN3 (Molex 22-23-2151)	
Pin #	Function	Pin #	Function
1	+5 V Output	1, 3, 5, 7, 9, 11	Lamp Connections
2, 3	+12 V Input	2, 4, 6, 8, 10, 12, 13, 14	No Connections
4	Dimming Control	15	Lamp Commons
5, 6	Ground		
7	On/Off Control		
Mating Housing - Molex 22-01-3077			

## Typical Electro-optical Performances

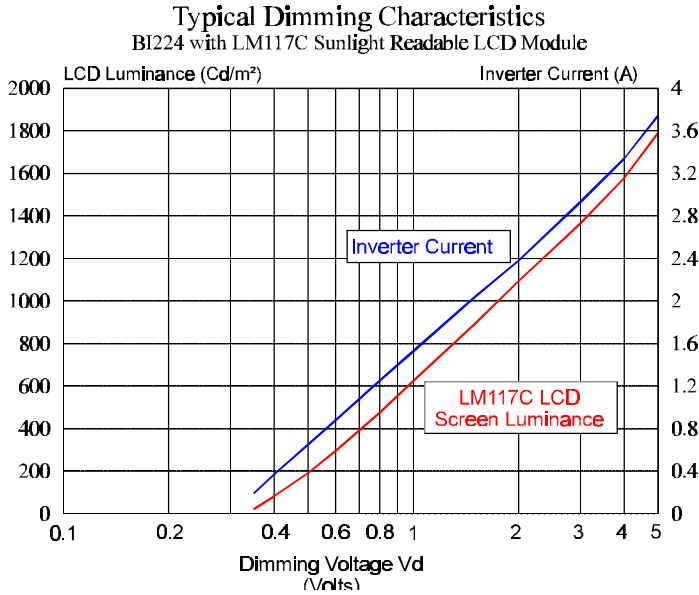

Fig. 2. Typical LCD Screen Luminance & Inverter Current vs. Dimming Voltage - LM117C-150XA-03 15" sunlight readable LCD module with BI224 inverter

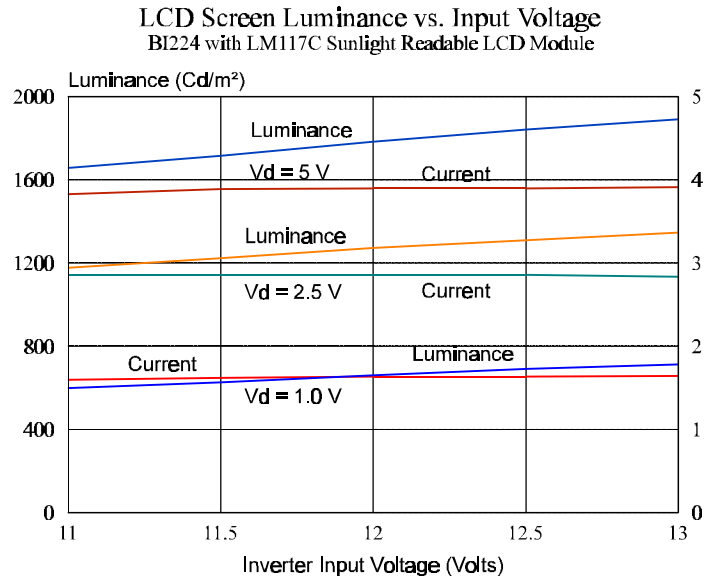
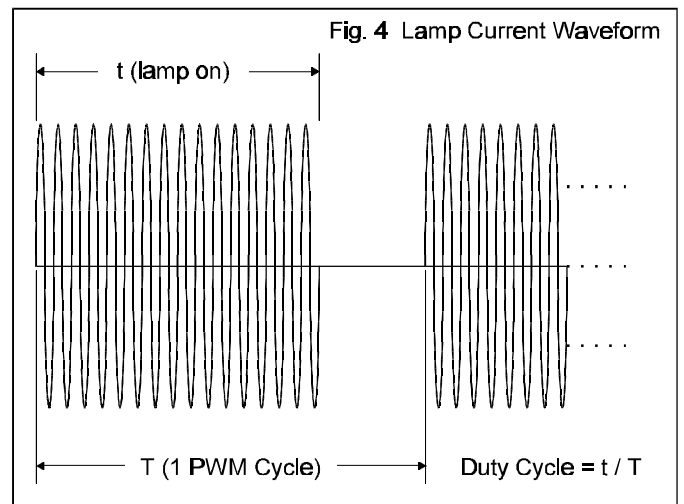

Fig. 3. Typical LCD Screen Luminance & Inverter Current vs. Input Voltage at various dimming settings - LM117C-150XA-03 15" sunlight readable LCD module with BI224 inverter

## Dimming Control

The BI224 accepts a 0 - 5V analog voltage for dimming control. Typical dimming characteristics with Landmark sunlight readable LCD modules are shown in the Fig 2.

The BI224 inverter has a pulse width modulation (PWM) dimming circuit for luminance adjustment. As the dimming voltage Vd decreases from +5V, the lamp current waveform is pulse width modulated at a repetition rate high enough to prevent LCD screen flicker. Within each PWM cycle, the lamps in the backlight are turned fully "ON" for a fraction of the cycle time. The human eyes, being very slow with respect to the PWM rate, respond to the average light produced over the PWM cycle. As a result, the luminance of the backlight and/or the LCD screen is



approximately proportional to the duty cycle of the PWM waveform.

## Dimming Control (continue)

In general, inverters with PWM dimming have a very wide luminance adjustment range. For most practical cases, the BI224 inverter can achieve a maximum dimming ratio of about 200:1. Hence, the luminance of the backlight or the LCD screen can be adjusted from 100% to 0.5%. Under certain conditions, the BI224 can achieve a dimming ratio much higher than 200:1. Please contact Landmark Technology for details on this feature.

The 0 - 5V dimming voltage can be generated simply by using a potentiometer or certian voltage step generating circuits as shown in Fig 5 and Fig. 6. The inverter has a regulated +5V supply (Pin #1 of the input connector CN1) to power the dimming circuit. However, the

maximum current drain from this source should be kept at less than 5 mA.

At a  $V_d$  input of about 560 mV, the duty cycle of the PWM waveform reaches 0% and thus, the lamps are “OFF”. In order to fully utilize the available dimming range,  $V_d$  should be biased to about 0.54V and then ramps up to 5.0V

The LCD luminance and the inverter current vary almost linearly if  $V_d$  is plotted in log scale (Fig. 2). Thus, it is recommended that a logarithmic voltage step generating circuit be used to provide a nearly linear luminance adjustment.

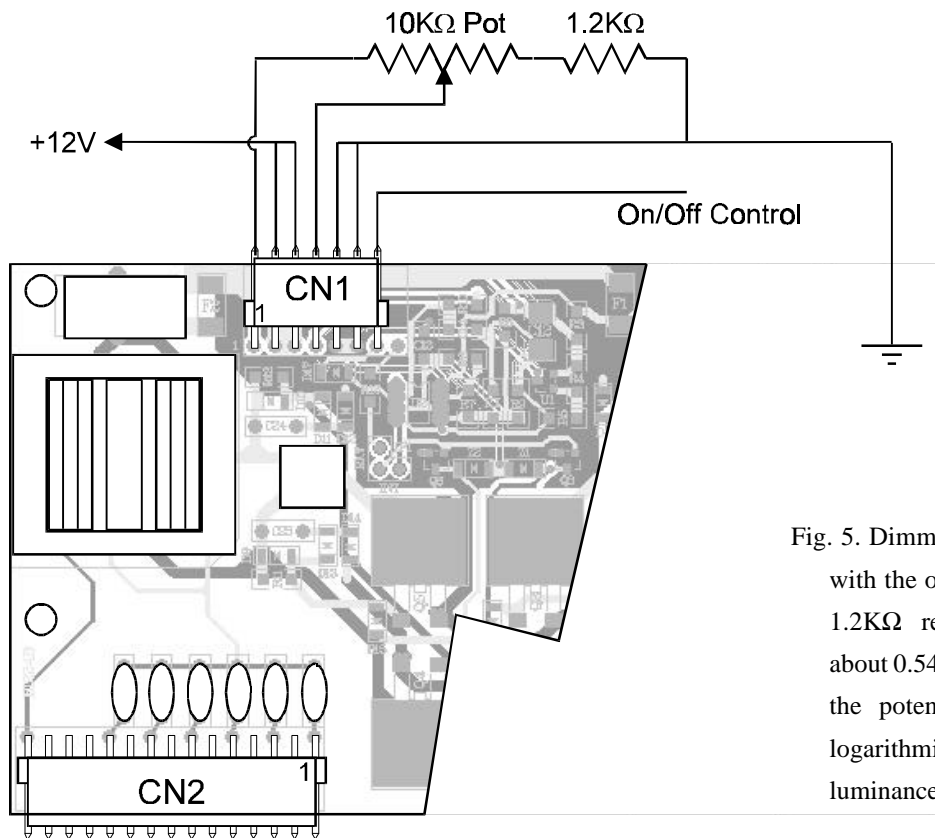

Fig. 5. Dimming control using a 10 KΩ potentiometer with the on-board +5V regulated supply. Adding a 1.2KΩ resistor in series sets the minimum  $V_d$  to about 0.54V. This allows the full adjustable range of the potentiometer for dimming control. Use a logarithmic potentiometer to have a nearly linear luminance adjustment,

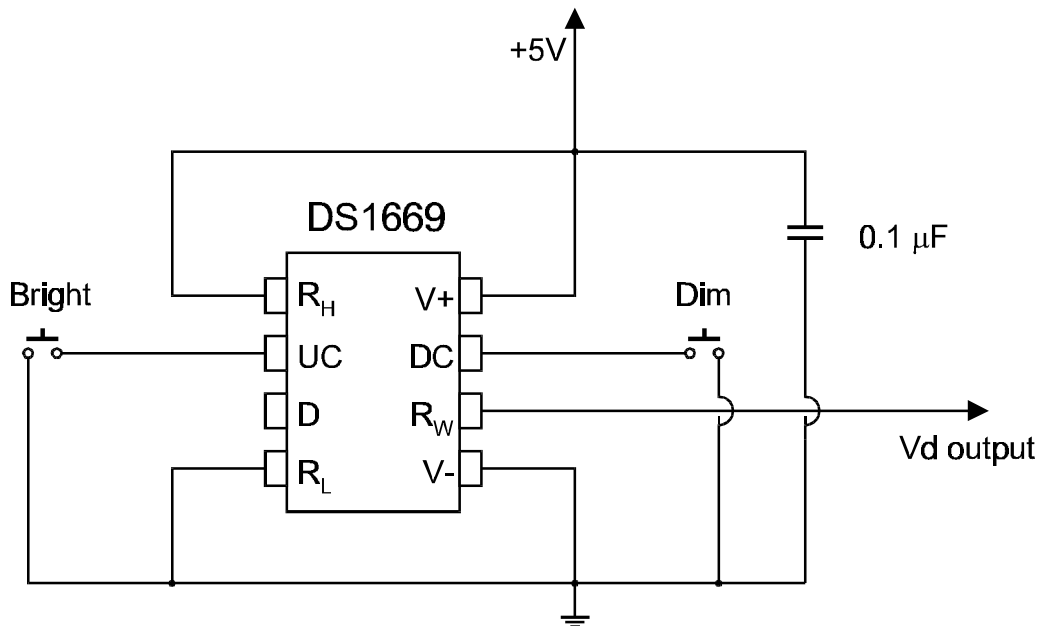

Fig. 6. Dimming voltage generation using a 6-bit digital potentiometer DS1669 from Dallas Semiconductor. This circuit provides 64 linearly distributed voltage steps from 0 to 5 V. To create a near logarithmic voltage distribution, connect a 10 K $\Omega$  resistor across the R<sub>w</sub> and V-. Since the current drain of the DS1669 chip is very small, the +5V regulated supply on the BI224 inverter can be used to power this circuit.

#### Disclaimer

Landmark Technology Inc. reserves the right to make changes to this document and the product which it describes without notice. In addition, Landmark Technology Inc. shall not be liable for technical or editorial errors or omissions made herein; nor for incidental or consequential damages resulting from the furnishing, performance, and use of this product.

This product shall not be used for or in connection with equipment that requires an extremely high level of reliability, such as military and aerospace applications, telecommunications equipment, nuclear power control equipment and medical or other life support equipment. Landmark Technology Inc. takes no responsibility for damage caused by improper use of this product or any other use which does not meet the conditions for use specified in this specification sheet.