

Introduction

LM177-170EG01 is a 17" sunlight readable LCD module. The module consists of an AUO M170EG01 TFT color LCD panel and a Landmark VHB (very high brightness) backlight. The module has the same foot print and uses the same mounting holes as the Landmark LM148-170EN sunlight readable LCD module.

At the maximum backlight power of 37 Watts, the LM177-170EG01 module delivers 1,200 Cd/m² (nits) of LCD screen luminance. At this brightness level, the display is highly readable under bright ambient lighting including direct outdoor sunlight. It is recommended that the Landmark BI320A inverter be used to operate the backlight in this LCD module. With this inverter, the LCD screen luminance can be adjusted down to 6 Cd/m² for night viewing.

Characteristics (Note 1, 2)

Parameters	Typical Value	Units	Conditions
LCD Screen Luminance	1,200	Cd/m ²	LCD in OFF state (normally White)
Luminance Uniformity	20% or better		Note 3
Backlight Power Consumption	39	Watts	Excluding inverter losses
Screen Luminance Dimming Ratio	200:1		With LMT BI320A inverter
Typical LCD Contrast Ratio	600:1		White vs. Black (measured in the dark along the normal direction)
Typical Viewing Angles			
3:00 direction	> 70	Degrees	Contrast ratio ≥ 10
9:00 direction	> 70	Degrees	Contrast ratio ≥ 10
6:00 direction	> 70	Degrees	Contrast ratio ≥ 10
12:00 direction	> 60	Degrees	Contrast ratio ≥ 10
LCD Screen Chromaticity (x, y)			
White	(0.342, 0.355)		Measured at the normal direction
Red	(0.632, 0.359)		Measured at the normal direction
Green	(0.276, 0.624)		Measured at the normal direction
Blue	(0.142, 0.091)		Measured at the normal direction
Response Speed			
Rise time	6	msec	White to Black, 10% - 90% transition
Fall time	2	msec	Black to White, 10% - 90% transition
LCD Module Weight	1,700	Grams	

Note 1: Please refer to AUO M170EG01 LCD Specification for detailed electrical specifications and general precautions.

Note 2: All data is measured at 25^o C ± 2^o C ambient temperature.

Note 3: Uniformity = (L_{max} - L_{min}) / (L_{max} + L_{min}) where L_{max} (L_{min}) is the maximum (minimum) luminance measured using a 10 mm diameter meter aperture over the LCD active area, except the last 10 mm area from the edges.

LCD Module Optical Performances

Luminance & Contrast Ratio

The typical LM177-170EG01 LCD module screen luminance and contrast ratio are shown in the figures below. Since this module is a normally white LCD, the screen luminance is measured with the LCD in the “Off” state (i.e. the pixels are not energized). This is the “white” state that provides the maximum possible luminance. The “white” color displayed on the screen when the video signal is applied may have a slightly lower luminance which can be caused by improper settings of the graphics card and/or the LCD controller. When the LCD is properly driven, the measured luminance of the “white” color displayed on the screen should be within 10% of the specified value.

LM177-170EG01 LCD Screen Luminance
Angular Distribution

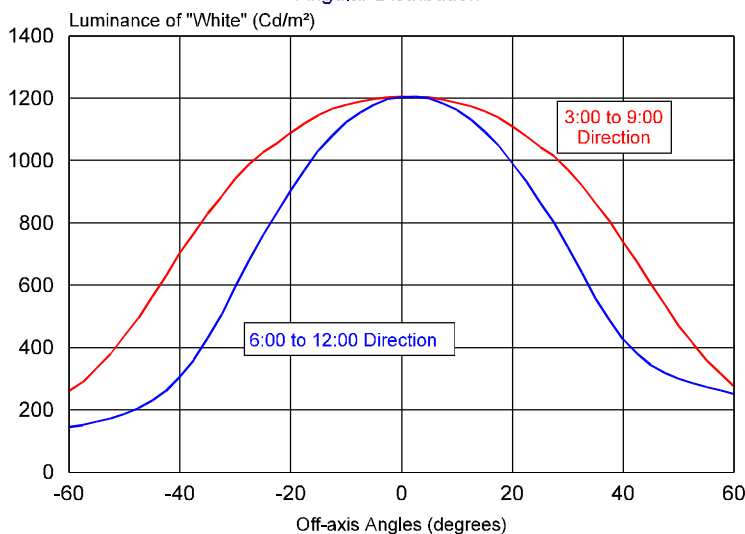

At the optimal viewing directions, the LM177-170EG01 LCD module has a contrast ratio (CR) of about 600:1. This is the inherent CR, which is the luminance ratio between the “White” and the “Black” states measured in a dark room. Under ambient lighting, particularly in bright outdoor environments, the CR value of the display drops significantly due to the reflection and glare caused by the strong ambient illumination.

Chromaticity

LM177-170EG01 is a normally white, film compensated TN LCD, yet it has a very wide viewing angle with small color shift.

The figures on the next page present the chromaticity (x, y) data of the R, G, B primary colors displayed on the screen.

LM177-170EG01 LCD Contrast Ratio
Angular Distribution

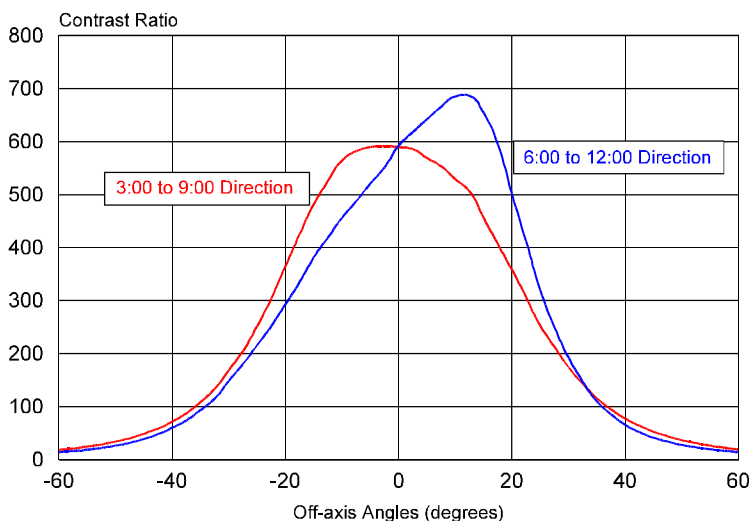

Along the 3:00 to 9:00 (horizontal) and the 6:00 (vertical) directions, the chromaticity shifts are quite insignificant up to 40 degree off-axis viewing angles. The shifts remain small even at viewing angles beyond 40 degrees. So, the color shifts along the horizontal directions and along the 6:00 vertical direction is quite small.

Along the 12:00 (vertical) direction, the chromaticity values of the Red and Blue primary colors do not change too much up to 40 degrees. However, the Green color shifts toward the White at viewing angles about 20° and beyond.

LM177-170EG01 Color Shift along the 3:00 - 9:00 Directions
(Positive Angles are along the 3:00 Direction)

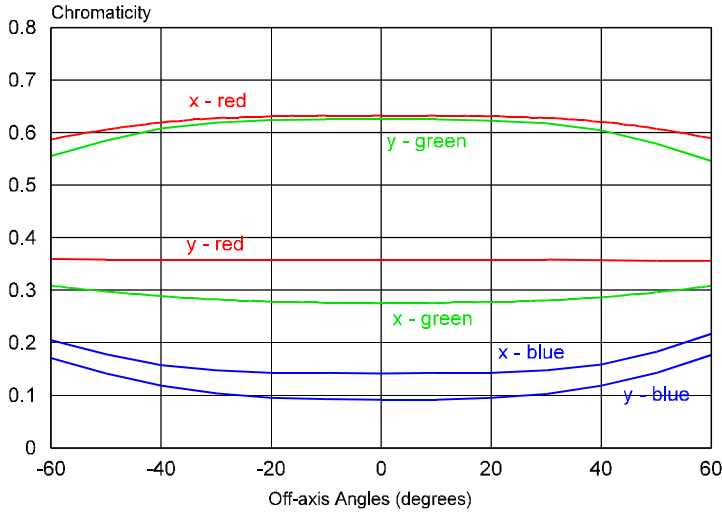

LM177-170EG01 Color Shift along the 6:00 - 12:00 Directions
(Positive Angles are along the 6:00 Direction)

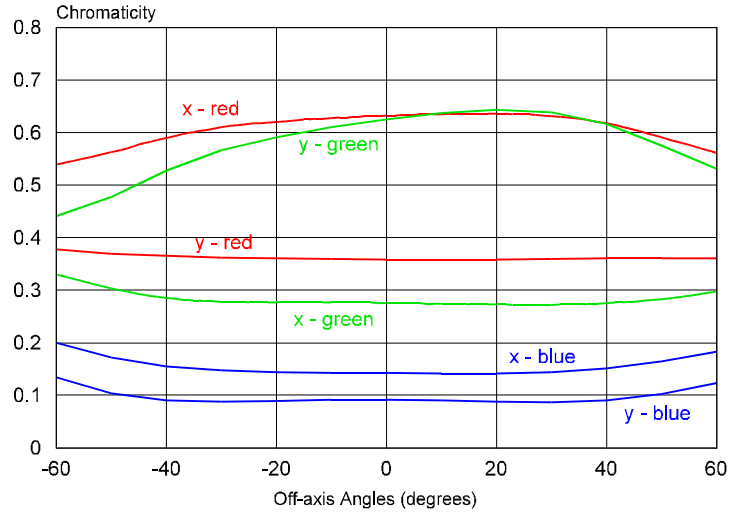

Backlight Lamp Driving Specifications

LM177-170EG01 VHB LCD has a VHB backlight with 12 cold cathode fluorescent lamps (CCFLs). The lamps are electrically connected into two groups through two 15-pin Molex connectors. The figure on the next page shows the connector pin out assignments.

It is recommended that an inverter with a minimum of 1700 V_{rms} starting voltage be used to run the VHB backlight on the LM177-170EG01 module. The lamp

voltage and current at full LCD screen luminance are listed below:

Lamp Voltage	595	V _{rms}
Lamp Current	5.5	mA _{rms}

At this driving condition, the backlight delivers 1,200 Cd/m² of LCD screen luminance with a power consumption of about 39 Watts.

Since most inverters have an efficiency level between 75 - 80%, the DC power input to the inverter is about 49 to 52 Watts. When the LCD luminance is adjusted down, the power consumption decreases.

The Landmark BI320A inverter is designed to drive the 12-CCFL backlight in the LM177-170EG01 module. The inverter has a PWM (pulse width modulation) circuit that provides a 200:1 screen luminance adjustment (i.e. from 1,200 to 6 Cd/m²). For detailed information, please refer to the BI320A data sheet.

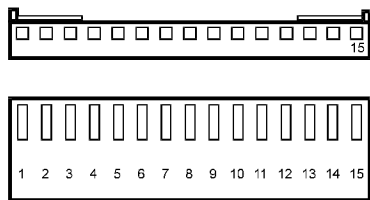

Group 1 Connector		Group 2 Connector	
Pin #	To	Pin #	To
1	Lamp #1	1	Lamp #7
2	NC	2	NC
3	Lamp #2	3	Lamp #8
4	NC	4	NC
5	Lamp #3	5	Lamp #9
6	NC	6	NC
7	Lamp #4	7	Lamp #10
8	NC	8	NC
9	Lamp #5	9	Lamp #11
10	NC	10	NC
11	Lamp #6	11	Lamp #12
12	NC	12	NC
13	NC	13	NC
14	NC	14	NC
15	COMMON 1	15	COMMON 2

Connector (Housing) Molex 22-01-3157
Two connectors per backlight

Mating Header: Molex 22-23-2151

Backlight Life

When the lamps in the LM177-170EG01 backlight are operating at the recommended current for full LCD screen luminance, they are rated at 25,000 hours half brightness life. The half brightness life is the number of operating hours before the CCFL surface luminance drops down to 50% of its initial value.

In general, the luminance of a backlight decays slightly faster than that of a CCFL. This is due to the aging of other materials in the backlight. However, in actual applications, the luminance of a VHB display will likely be adjusted down in dimly lit environments. Since the half brightness life increases rapidly when lamps are operated at reduced current levels for lower LCD screen luminance, the actual operating lifetime of the backlight in this LCD module can be expected to reach beyond 25,000 hours. For detailed descriptions on backlight life issues and actual test data on Landmark Technology backlights, please refer to Technical Note TK801

Thermal Management

The backlight power consumption of the LM177-170EG01 LCD module is approximately 39 Watts at full brightness. As a result, the LCD screen temperature will be higher than normal. It is necessary to dissipate the backlight heat such that the LCD temperature stays within the temperature specifications of the AUO M170EG01 LCD.

The exact increase in screen temperature depends on the installation of the LCD module in the equipment. For example, with the LM177-170EG01 operating at full brightness in open air with no air flow (still air), the average temperature of the LCD front surface is about 15 to 20 °C above the ambient air temperature. The highest temperature rise usually occurs if the LCD is placed horizontally. If the LCD is placed vertically, a portion of the heat may rise and dissipate into the air without heating up the LCD. When the LCD is mounted on a heat conducting bezel or a cooling fan is used, the screen temperature rise can be significantly reduced.

It is recommended that the LCD screen temperature be measured at full brightness in the equipment under actual operating environments. The cooling measure should then be designed accordingly. Please make sure that the specified maximum LCD temperature is not exceeded.

If the thermal issue becomes difficult to resolve, it is possible to run the LM177-170EG01 module at a lower brightness to reduce the backlight power. For example, if the PWM dimming circuit of the BI320A inverter is set at a 65% duty cycle, the LCD screen luminance is about 780 nits and the backlight power will be reduced by about 35%. As a result, the thermal related issues are reduced proportionally.

Caution:

LM177-170EG01 is a side mount LCD module. Please use screws of proper size and length for LCD mounting. Excessively long screws can cause severe damage to the LCD module. Please follow the drawing on the right as a guideline for the proper screw length.

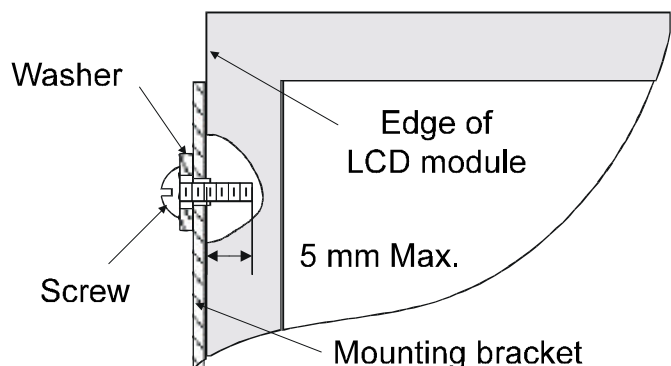

Disclaimer

Landmark Technology Inc. reserves the right to make changes to this document and the product which it describes without notice. In addition, Landmark Technology Inc. shall not be liable for technical or editorial errors or omissions made herein; nor for incidental or consequential damages resulting from the furnishing, performance, and use of this product.

This product shall not be used for or in connection with equipment that requires an extremely high level of reliability, such as military and aerospace applications, telecommunication equipment, nuclear power control equipment and medical or other life support equipment. Landmark Technology Inc. takes no responsibility for damage caused by improper use of this product which does not meet the conditions for use specified in this specification sheet.

LCD Module Mechanical Dimensions

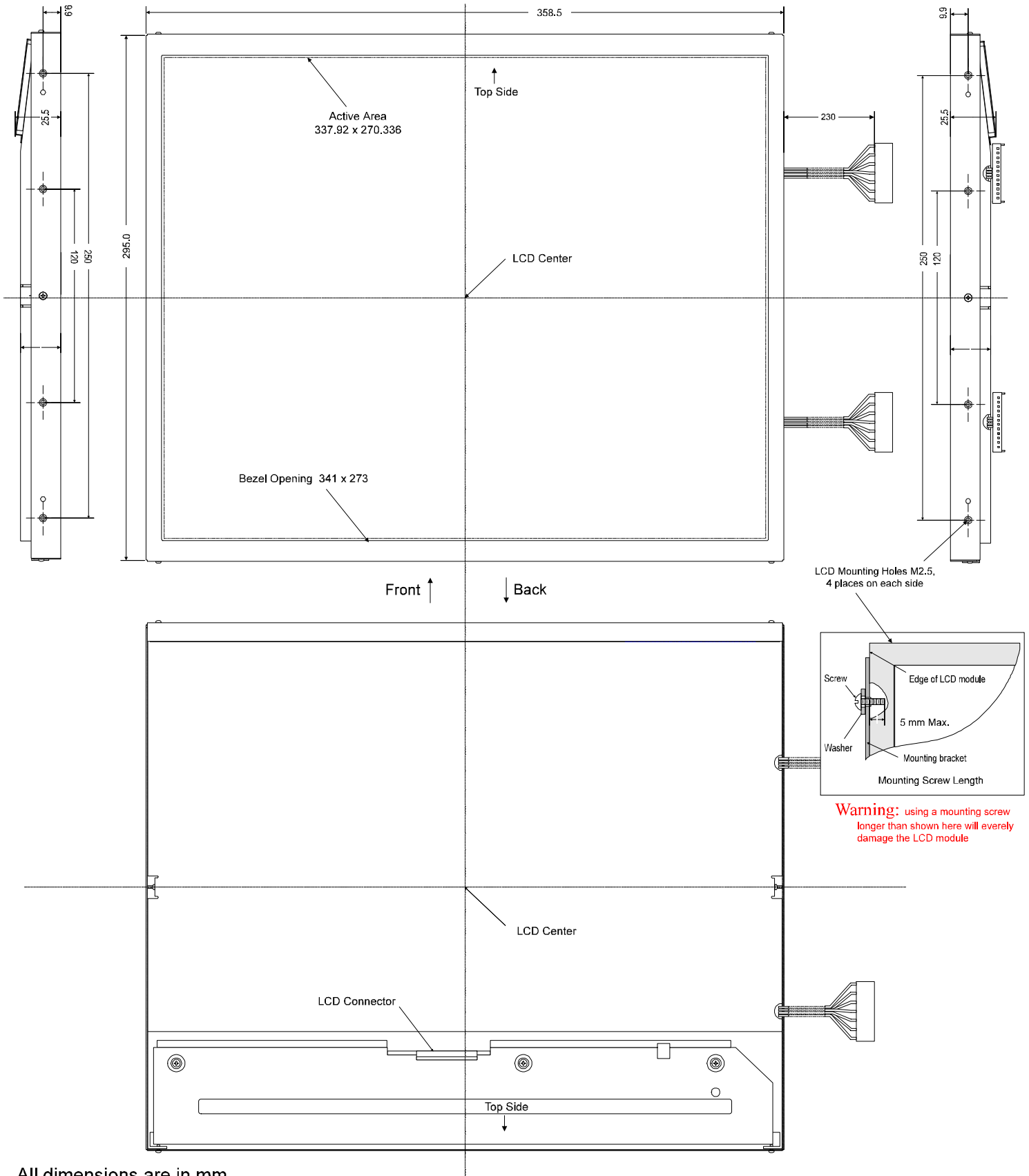

Warning: using a mounting screw longer than shown here will everely damage the LCD module

All dimensions are in mm