

Introduction

PS200 is a photosensor board for automated control of LCD screen luminance as the ambient illumination changes.

On the front side of the PS200 board, there is a photoconductive cell that senses the ambient light and outputs a dimming voltage to a Landmark inverter for LCD screen luminance adjustment. On the backside of the board, there is a trimmer pot for fine tuning the dimming characteristics for various ambient lighting conditions.

The PS200 board can be used with Landmark BI206, BI224, BI320, and BI330 inverters.

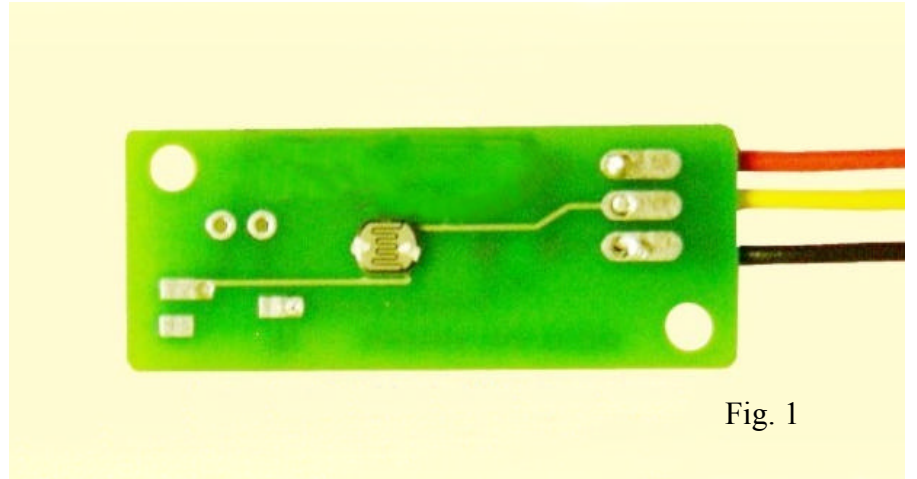

Fig. 1

Connecting to the Inverter

There are three wire connections on the PS200 photosensor board:

Wire Color	Connect to
Red	+12V
Yellow	Inverter dimming input
Black	Ground

Figure 2 below illustrates the connections to the input connector CN1 of the inverter. Please refer to the Landmark Inverter data sheet for the detailed pin assignment of the CN1 connector and the Molex part number of the mating connector.

The maximum current needed from the 12V supply to power the PS200 photosensor is about 11 mA.

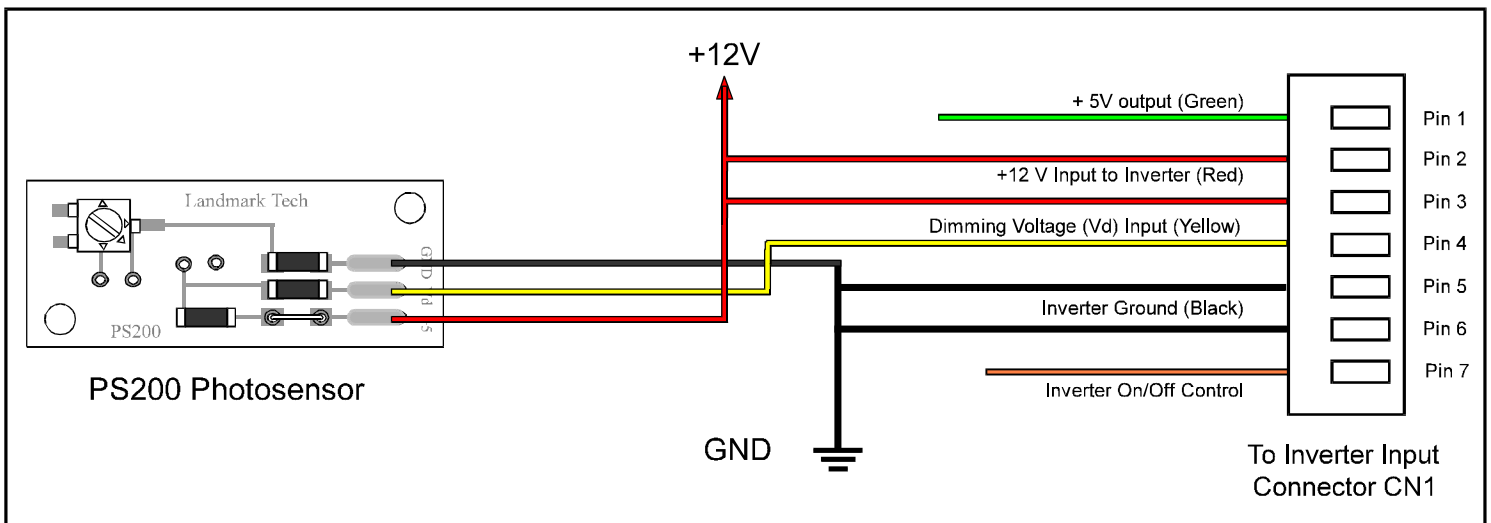

Typical Characteristics

The typical dimming characteristics of the PS200 photosensor is shown in Figure 3. The horizontal axis is the ambient illumination incident on the photoconductive cell. The vertical axis is the LCD screen luminance as the percent of its maximum level. There are five curves in Figure 3 corresponding to five trimmer pot resistance (R_t) settings at 0, 30, 60, 100, and 200 Ohms respectively. Setting the trimmer pot at 0 Ohm provides the widest LCD luminance adjustable range. To cite an example, if the maximum LCD luminance is $1,500 \text{ Cd/m}^2$, then as the ambient illumination (on the photo cell) drops to 1,000 Lux (typical bright indoor ambient), the LCD luminance is reduced to 53% or about 800 Cd/m^2 . At nearly total darkness (0.1 Lux), the LCD luminance is reduced to 1.2% or 18 Cd/m^2 . Therefore, the total dimming range is close to 100:1. On the other hand, if a brighter display is needed at low ambient lighting levels, the trimmer pot can be adjusted to a higher R_t value to increase the LCD screen luminance. For example, when the trimmer resistance is increased to 200 Ohms, the screen luminance at near total darkness is 12.3% or 170 Cd/m^2 .

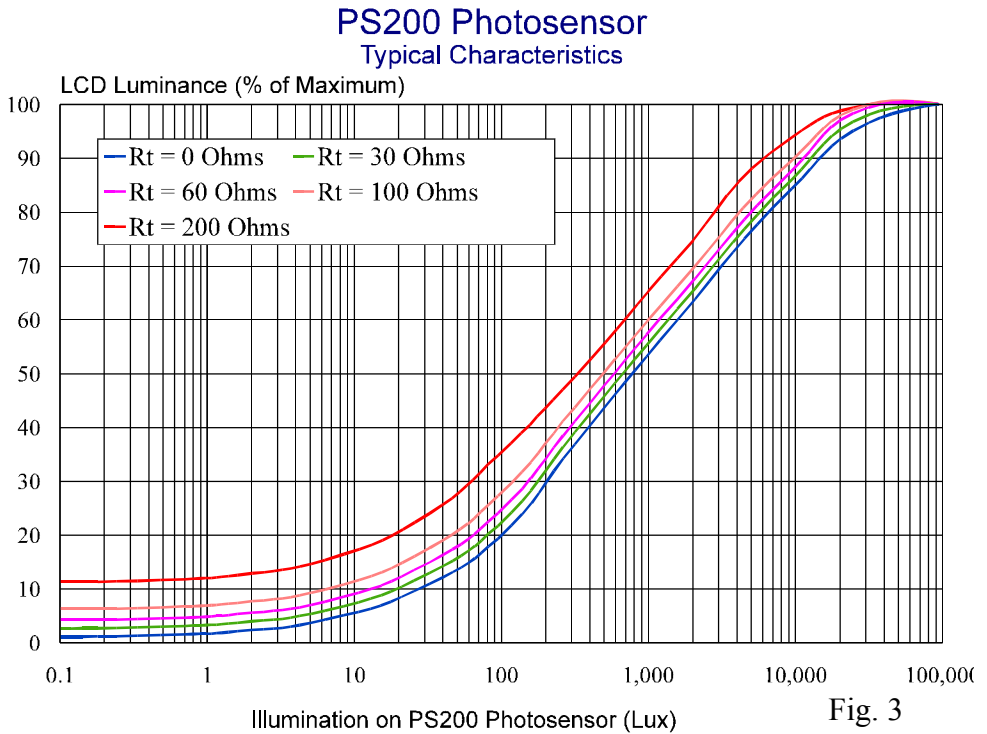

Mechanical Dimensions

The mechanical dimensions of the PS200 photosensor board is shown in Figure 4 on the right.

Installation

The PS200 photosensor can be installed on the backside of the display face plate. The photo cell should be aligned with an opening or window on the face plate to sense the ambient light level. If the arrangement of the photo cell on the PS200 board does not match to the design of the display face plate well, please call Landmark Technology for certain alternative ways to arrange the photo cell.

