



AND-TFT-pSi025TP-LED

2.5" Color p-Si TFT LCD Module (Transmissive)

The AND-TFT-pSi025TP-LED is a 882 x 228 Color TFT display that utilizes new LTPS (Low Temperature Poly Silicon) technology to provide brighter, thinner and lighter display with high luminance. The 2.5" (6.35 cm) LCD module is an active matrix color TFT LCD module with Analog Interface. Vertical and horizontal drivers are built on the panel. NTSC and PAL format are compatible. All these features making it ideal for portable applications including personal digital assistants (PDAs), medical instruments and test & measurements instruments.

Features

- Low Temperature Poly Silicon (LTPS) construction
- High luminance, low power consumption
- Horizontal scan can be left to right or right to left
- Vertical scan can be up to down or down to up
- Minimal external circuits and components
- Slim and lightweight design
- Transmissive display
- Applications: portable, battery-operated applications

Mechanical Characteristics

Item	Specification	Unit
Display Size (diag.)	2.5 (6.35cm)	inch
Display Type	Transmissive	-
Active Area	49.42 (W) x 38.304 (H)	mm
Number of Dots	882 (W) x 228 (H)	dot
Dot Pitch	0.056 (W) x 0.168 (H)	mm
Color Arrangement	RGB Delta	-
Color Numbers	16 Million/ Full Color	-
Outline Dim. (W x H x D)	59.1 x 45.3 x 3(Approach)*	mm
Weight	16(Approach)	g

* Exclude FPC and protrusions.

Absolute Maximum Ratings (GND=0V)

Item	Symbol	Min.	Max.	Unit
Power Supply for Horizontal Driver	HVDD	-1.0	+14	V
Power Supply for Vertical Driver	VVDD	-1.0	+14	V
Vertical Driver Neg. Power Supply Voltage	VVEE	-6.0	-1.0	V
Common Electrode Voltage	VCOM	-1.0	+14	V
Horizontal Driver / Precharge Data Input Voltage	STH, XSTH, CKH1, CKH2, CSH, PCG, XPCG	-1.0	+14	V
Vertical Driver / Precharge Data Input Voltage	STV, XSTV, CKV1, CKV2, CSV, ENB, XENB	-1.0	+14	V
Video / Precharge Data Input Voltage	VG, VR, VB, VPCD	-1.0	+14	V
Operating Temp.	Topr	-10	+60	°C
Storage Temp.	Tstg	-30	+80	°C

Driving Backlight (Ta = 25°C)

Item	Symbol	Min.	Typ.	Max.	Unit	Remarks
Forward Current	I _F	-	20	-	mA	Note 1
Forward Current Voltage	V _F	-	14.4	16	V	
Backlight Power Consumption	W _{BL}	-	288	-	mW	

Note 1: Backlight driving circuit is recommended as the fix current circuit.

Product specifications contained herein may be changed without prior notice. It is therefore advisable to contact Purdy Electronics before proceeding with the design of equipment incorporating this product.

Dimensional Outline

Front View

Unit: mm
Standard Tolerance: 0.5mm

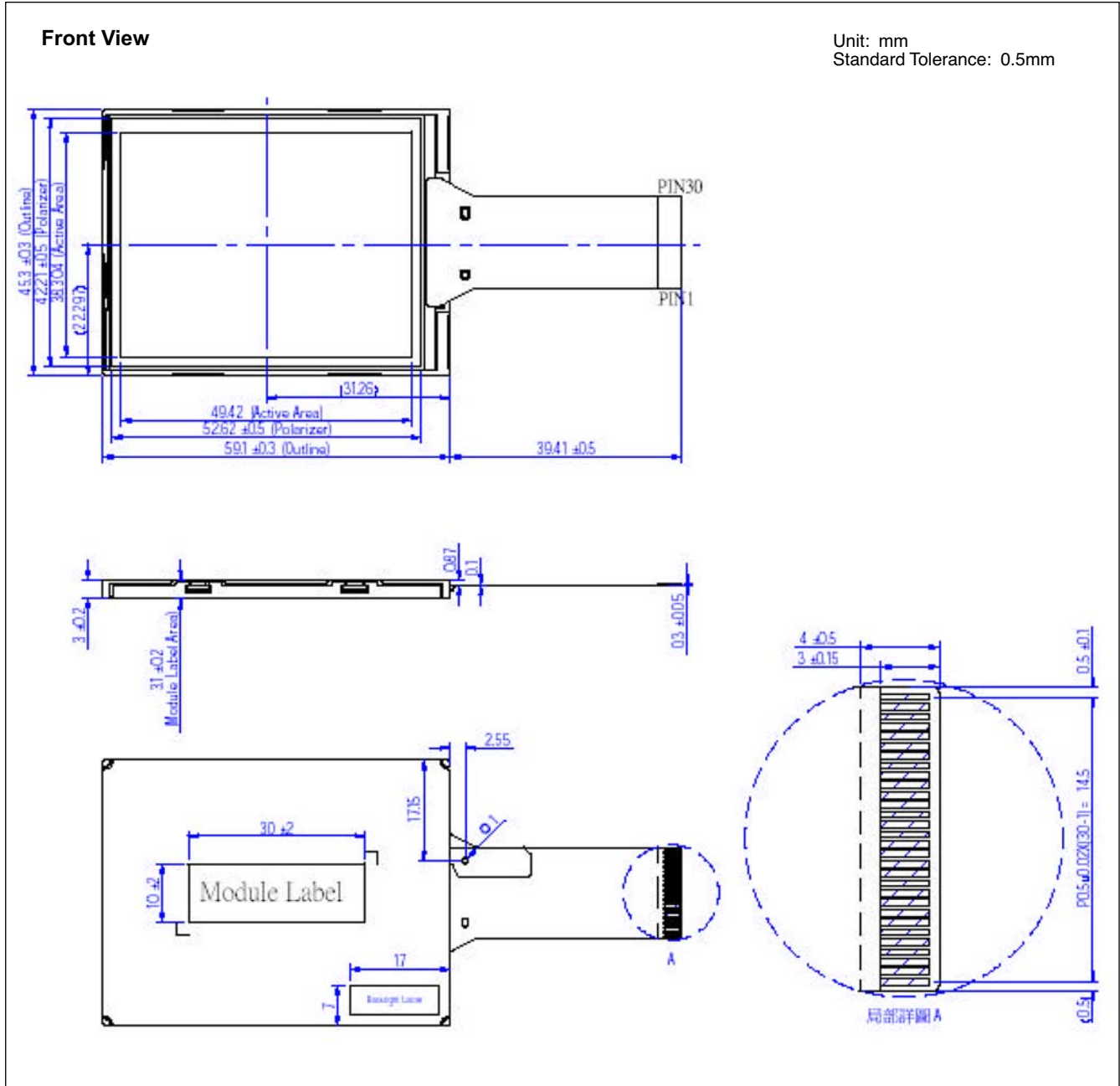

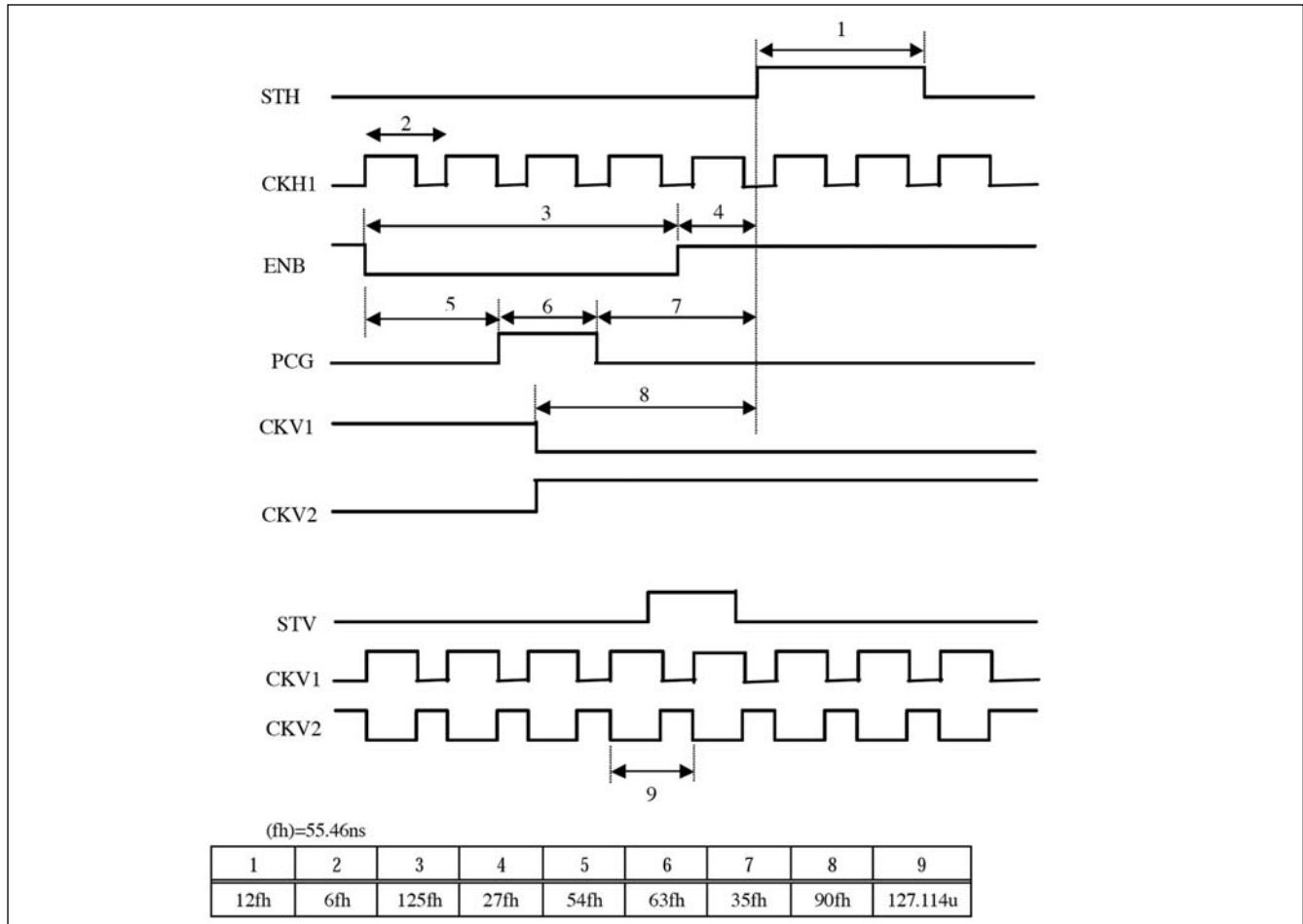
Timing Chart

Optical Specification - See Notes below Ta=25°C

Item	Symbol	Condition	Min.	Typ.	Max.	Unit	
Viewing Angles	Θ 11	CR = 10	35	45	–	degree	
	Θ 12		35	45	–		
	Θ 21		12	17	–		
	Θ 22		35	45	–		
Contrast Ratio	CR	Θ = 0°	120	200	–	–	
Response Time	Rising		Tr	–	15	25	–
	Falling		TF	–	25	45	–
Luminance (IF=20mA)	L		200	250	–	cd/m ²	
Chromaticity	White		x _w	0.26	0.31	0.36	–
		y _w	0.29	0.34	0.39		

Note 1: Driving voltage with Digital Interface: HVDD = 8.5V, VVDD = 8.5V

VVC = 2.6V, VCOM = Optimum common electrode voltage

Driving voltage with Analog Interface: HVDD = 12.0V, VVDD = 12.0V

VVC = 5.2V, VCOM = Optimum common electrode voltage

Note 2: Ambient Temperature: ta = 25°C

Note 3: Testing Point: Measure in the display center point and the test angle Θ = 0°

Note 4: R, G, B signal input voltage VG, VR, VB; VG, VR, VB = VVC ± VAC (VAC: Signal Amplitude)

Note 5: LED Current: I_F = 20mA.

**Input/Output Terminals
TFT LCD Panel**

Pin	Symbol	I/O	Description	Remarks
1	NC	–	No Connection	
2	V _{FS}	I	GND for LED Backlight	
3	V _F	I	LED Input Voltage	
4	NC	–	No Connection	
5	NC	–	No Connection	
6	NC	–	No Connection	
7	VCOM	I	Common Electrode Voltage	
8	CKV1	I	Vertical Clock 1	
9	CKV2	I	Vertical Clock 2	
10	STV	I	Vertical start signal	
11	XSTV	I	Inverted signal of STV	
12	VVDD	I	Power SUPply for Vertical Driver	
13	ENB	I	Enable signal	
14	XENB	I	Inverse signal of ENB	
15	CSV	I	Up/Down inverse control signal	
16	VBB	O	Vertical driver output power voltage	VBB be used for digital interface; NC be used for analog interface.
	NC	–	No Connection	
17	PCG	I	Precharge data signal	
18	XPCG	I	Inverted signal of PCG	
19	PCD	I	Precharge data signal for pixel	
20	B	I	Video Signal (B)	
21	R	I	Video Signal (R)	
22	G	I	Video Signal (G)	
23	CSH	I	Right/Left inverse control signal	
24	VVEE	I	Vertical driver negative power supply voltage	VVEE be used for digital interface; VSS be used for analog interface.
	VSS	I	GND	
25	VSS	I	Ground	
26	STH	I	Horizontal start signal	
27	XSTH	I	Inverse signal of STH	
28	HVDD	I	Power SUPply for Horizontal Driver	
29	CKH1	I	Horizontal Clock 1	
30	CKH2	I	Horizontal Clock 2	

Electrical Characteristics - Driving TFT LCD Panel with Digital Interface

Item	Symbol	Min.	Typ.	Max.	Unit	
Power Supply for Horizontal Driver	HVDD	8.2	8.5	8.8	V	
Power Supply for Vertical Driver	VVDD	8.2	8.5	8.8	V	
Vertical Driver Neg. Pwr Supply Voltage	VVEE	-	-4.0	-	V	
Horiz. Driver Input Voltage	Low	VHIL	-0.3	0.0	0.3	V
	High	VHIH	2.5	3.0	4.0	V
Vert. Driver Input Voltage	Low	VVIL	-0.3	0.0	0.3	V
	High	VVIH	2.5	3.0	4.0	V
CSH, CSV	Low	VSIL	-0.3	0.0	0.3	V
	High	VSIH	8.2	8.5	8.8	V
Video Signal Center Voltage	VVC	2.4	2.6	2.8	V	
Video Signal Voltage	Blk (H)	Vblock(H)	4.0	4.2	4.6	V
	Blk (L)	Vblock (L)	0.8	1.0	1.2	V
	Wh-Bk	V sig w-b	-	-	3.00	V
Common Electrode Signal Ctr Voltage	VCOMc	(VVC-0.2) -0.2	(VVC0.2)	(VVC-0.2) +0.2	V	
Common Electrode Signal Ctr Range	VCOMp-p	-	3.8	-	V	
Panel Power Consumption	W _P	13	20	26	mW	

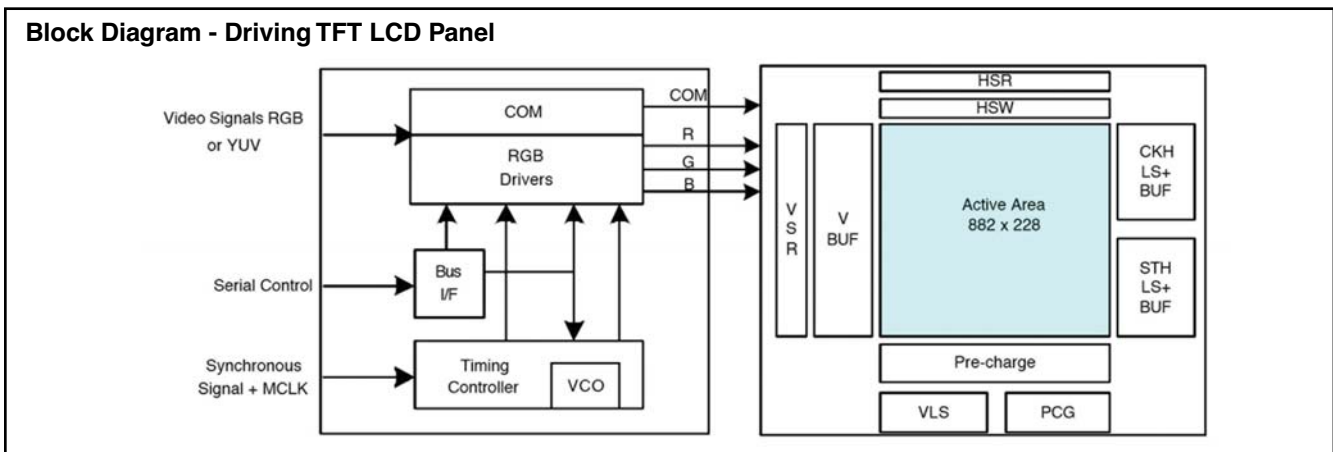
Block Diagram - Driving TFT LCD Panel

Electrical Characteristics (VSS=0V, Ta = 25°C) Driving TFT LCD Panel with Analog Interface

Item	Symbol	Min.	Typ.	Max.	Unit	Remarks	
Power Supply for Vertical Driver	VVDD	11.7	12	12.3	V		
Power Supply for Horiz. Driver	HVDD	11.7	12	12.3	V		
Horizontal Driver Input Voltage	Low	VHIL	-0.3	0.0	0.3	V	
	High	VHIH	2.5	3.0	4.0	V	
Vertical Driver Input Voltage	Low	VVIL	-0.3	0.0	0.3	V	
	High	VVIH	2.5	3.0	4.0	V	
CSH, CSV	Low	VSIL	-0.3	0.0	0.3	V	
	High	VSIH	11.5	12	12.3	V	
Video Signal Center Voltage	VVC	5.0	5.2	5.4	V	Note 1	
Video Input Voltage Range	VG, VR, VB	VCC -3.5	-	VVC +3.5	V		
Common Electrode Voltage	VCOM	-	VVC -0.2	-	V	Note 2	
Panel Power Consumption	W _P	35	50	65	mW		

Note 1: Video signal and Precharge data signal shall be input symmetrically around VVC.

Note 2: Set common electrode voltage to the optimum voltage.