

ANDpSi04C380K-HB

Custom 4" VGA Color p-Si TFT-LCD Integrated Display Module

The ANDpSi04C380K-HB is a custom VGA (640 x 480) color p-Si TFT-LCD panel with a 4" diagonal viewing area, integrated resistive touch panel and an integrated 24 LED array backlight unit. Poly-silicon based LCD technology enables the high resolution of 202 dpi, offering a photograph grade display. In addition, LED array based backlight system offers high luminance, long-life and power efficiency as well as mechanical robustness compared to CCFL based systems. The resistive touch panel completes the feature set, making this custom display module a perfect fit for portable computing devices with high information content needs.

Features

- p-Si construction with drivers on glass
- Wide viewing angle ($\pm 45^\circ$ at CR> 30)
- High luminance, long-life LED backlight
- Super high resolution (202 pixels/inch) VGA display
- 6-Bit digital R, G & B
- Thin and lightweight design
- Integrated 4-wire resistive touch panel
- Applications include portable instruments and PDAs

Mechanical Characteristics

Item	Specification	Unit
Outline Dimensions	118 (W) x 73 (H) x 6 max (D)	mm
Number of Pixels	640 (W) x 480 (H)	pixels
Active Area	80.64 (W) x 60.48 (H)	mm
Pixel Pitch	0.126 (W) x 0.126 (H)	mm
Weight (approx.)	tdb	gram
Backlight	24 (4p6s) LED array	-

Absolute Maximum Ratings

Item	Symbol	Min.	Max.	Unit
Supply Voltage	V_{DD}	0.0	4.5	V
	V_{LED}	-	22.5	V
Input Signal Voltage	V_{IN}	-0.3	$V_{DD} + 0.3$	V
Operating Temperature	T_{op}	0	50	$^\circ\text{C}$
Storage Temperature	T_{stg}	-20	60	$^\circ\text{C}$
Humidity (Max. Wet bulb temp = 29 $^\circ\text{C}$)	-	10	90	% RH

Product specifications contained herein may be changed without prior notice. It is therefore advisable to contact Purdy Electronics before proceeding with the design of equipment incorporating this product.

Electrical Characteristics (Ta = 25 $^\circ\text{C}$)

Item	Symbol	Min.	Typ.	Max.	Unit
Supply Voltage	V_{DD}	3.0	3.3	3.6	V
	V_{LED}	-	-	22.5	V
High Level Input Voltage	V_{IH}	0.8x V_{DD}	-	V_{DD}	V
Low Level Input Voltage	V_{IL}	0	-	0.2x V_{DD}	V
Current Consumption	I_{DD}	-	115	-	mA
	I_{LED}	-	120	-	mA
Power Consumption (*1)	P	-	-	4.2	W

*1: 8 color bars pattern

Optical Characteristics (Ta = 25 $^\circ\text{C}$)

Item	Symbol	Min.	Typ.	Max.	Unit
Contrast	CR	100	250	-	-
Response	t_{on}	-	-	50	ms
	t_{off}	-	-	50	ms
Luminance	L	-	200	-	cd/m ²
Viewing Angle (CR>30)	fL/ fR	40/40	45/45	-	deg
	fU/ fD	45/45	50/50	-	deg

Touch Panel Characteristics

Item	Specification
Operating Voltage Range	3 ~ 7 V
Current Consumption	5 ~ 25 mA
Surface Hardness	3H
Linearity	< 1.5%
Surface Finish	Anti-glare
Endurance	> 1M strikes

Timing Specifications (*1*2*3)

Item	Symbol	Min	Typ	Max	Unit
Frame Period	t1	489 x t3 -	525 x t3 16.68	525 x t3 17.85	- ms
Vertical Display Term	t2	480 x t3	480 x t3	480 x t3	t2 = N · t3
One Line Scanning Time	t3	784 x t5 31.5	800 x t5 31.78	860 x t5 36.5	- μs
Horizontal Display Period	t4	640 x t5	640 x t5	640 x t5	-
Clock Period	t5	35.0	39.72	46.5	ns
Clock "L" Time	t6	10.0	-	-	ns
Clock "H" Time	t7	7.0	-	-	ns
Set Up Time	t8	5.0	-	-	ns
Hold Time	t9	10.0	-	-	ns

Note 1: When ENAB is fixed to "H" level or "L" level after NCLK input, the panel is displayed as black. However, it may be occurred a flicker on the display.
 Note 2: When NCLK is fixed to "H" level or "L" level, the panel becomes white stage after several seconds.
 Note 3: Do not change t1 and t3 values in the operation. When t1 or t3 is changed, the panel is displayed as black.

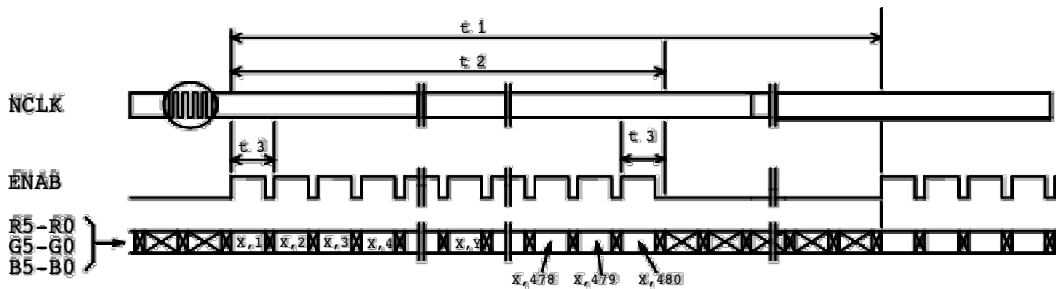
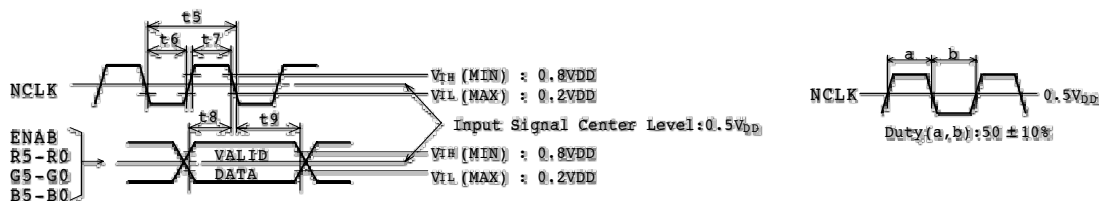
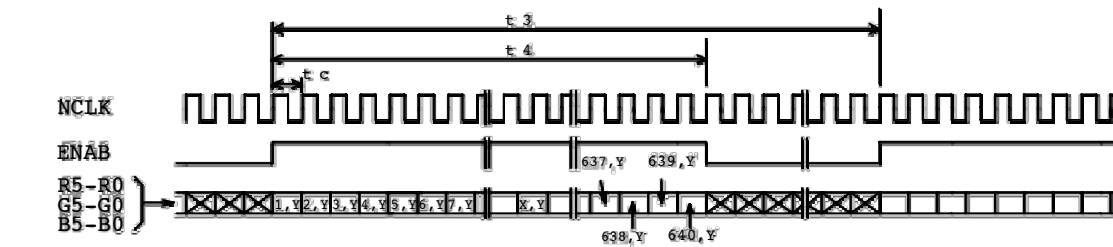
Timing Chart
(1) Vertical Timing

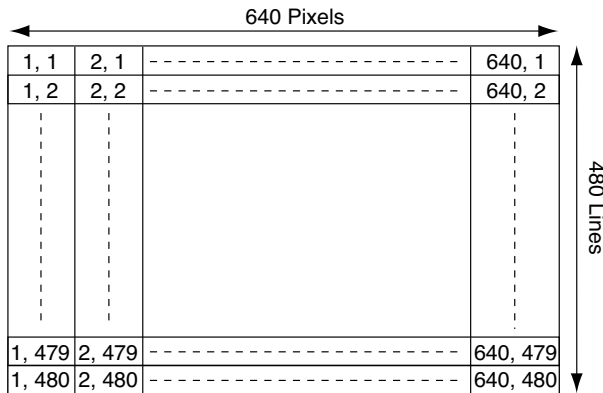
(2) Horizontal Timing

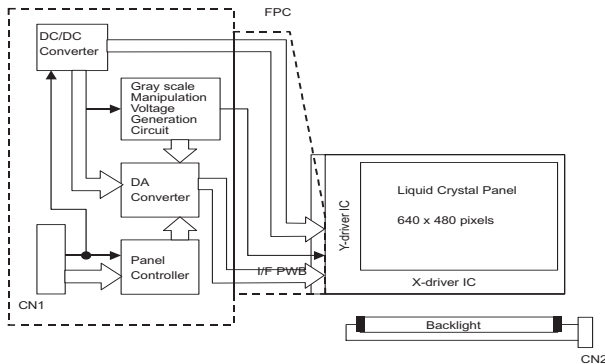

Recommended Inverter: TBD

Block Diagram



1) Drivers are fabricated on the LCD glass

2) Connectors

CN1

IL-FHJ-27S-HF / JAE

Mating connector: FFC (0.3mm pitch)

CN2

PHR-2 / JST

Mating connector: B2B-PH-SM3-TB / JST

CN3

FFC (1.0mm pitch)

Mating connector: 04MN-BMT-TF / JST

Connector Pin Assignments for Interface CN1; LCD Input Signals

Terminal No.	Symbol	Function
1	VDD	+3.3V Power Supply
2	VDD	+3.3V Power Supply
3	VDD	+3.3V Power Supply
4	ENAB	Compound Synchronization Signal
5	B5 ⁽²⁾	Blue Display Data (MSB)
6	B4 ⁽²⁾	Blue Display Data
7	B3 ⁽²⁾	Blue Display Data
8	B2 ⁽²⁾	Blue Display Data
9	B1 ⁽²⁾	Blue Display Data
10	B0 ⁽²⁾	Blue Display Data (LSB)
11	GND	Ground
12	G5 ⁽²⁾	Green Display Data (MSB)
13	G4 ⁽²⁾	Green Display Data
14	G3 ⁽²⁾	Green Display Data
15	G2 ⁽²⁾	Green Display Data
16	G1 ⁽²⁾	Green Display Data
17	G0 ⁽²⁾	Green Display Data (LSB)
18	GND	Ground
19	R5 ⁽²⁾	Red Display Data (MSB)
20	R4 ⁽²⁾	Red Display Data
21	R3 ⁽²⁾	Red Display Data
22	R2 ⁽²⁾	Red Display Data
23	R1 ⁽²⁾	Red Display Data
24	R0 ⁽²⁾	Red Display Data (LSB)
25	GND	Ground
26	NCLK	Sampling Clock
27	GND	Ground

Note (2): 256K colors are displayed by the combinations of 18 data bits.

CN2; LED Backlight Power Supply

Terminal No.	Symbol	Function
1	V _{LED}	+22.5V Power Supply
2	V _G	Ground

CN3; Touch Panel Interface

Terminal No.	Function
1	Top Electrode
2	Left Electrode
3	Bottom Electrode
4	Right Electrode

	Display	R5	R4	R3	R2	R1	R0	G5	G4	G3	G2	G1	G0	B5	B4	B3	B2	B1	B0	Gray Scale Level
Basic Color	Black	L	L	L	L	L	L	L	L	L	L	L	L	L	L	L	L	L	L	-
	Blue	L	L	L	L	L	L	L	L	L	L	L	L	H	H	H	H	H	H	-
	Green	L	L	L	L	L	L	H	H	H	H	H	H	L	L	L	L	L	L	-
	Lt. Blue	L	L	L	L	L	L	H	H	H	H	H	H	H	H	H	H	H	H	-
	Red	H	H	H	H	H	H	L	L	L	L	L	L	L	L	L	L	L	L	-
	Purple	H	H	H	H	H	H	L	L	L	L	L	L	H	H	H	H	H	H	-
	Yellow	H	H	H	H	H	H	H	H	H	H	H	H	L	L	L	L	L	L	-
	White	H	H	H	H	H	H	H	H	H	H	H	H	H	H	H	H	H	H	-
Gray Scale of Red	Black	L	L	L	L	L	L	L	L	L	L	L	L	L	L	L	L	L	L	L0
	Dark ↑ ↓	L	L	L	L	L	H	L	L	L	L	L	L	L	L	L	L	L	L	L1
		L	L	L	L	H	L	L	L	L	L	L	L	L	L	L	L	L	L	L2
		:	:	:	:	:	:	:	:	:	:	:	:	:	:	:	:	:	:	L3~L60
		:	:	:	:	:	:	:	:	:	:	:	:	:	:	:	:	:	:	
	Light	H	H	H	H	L	H	L	L	L	L	L	L	L	L	L	L	L	L	L61
		H	H	H	H	H	L	L	L	L	L	L	L	L	L	L	L	L	L	L62
	Red	H	H	H	H	H	H	L	L	L	L	L	L	L	L	L	L	L	L	Green L63
Gray Scale of Green	Black	L	L	L	L	L	L	L	L	L	L	L	L	L	L	L	L	L	L	L0
	Dark ↑ ↓	L	L	L	L	L	L	L	L	L	L	L	H	L	L	L	L	L	L	L1
		L	L	L	L	L	L	L	L	L	L	H	L	L	L	L	L	L	L	L2
		:	:	:	:	:	:	:	:	:	:	:	:	:	:	:	:	:	:	L3~L60
		:	:	:	:	:	:	:	:	:	:	:	:	:	:	:	:	:	:	
	Light	L	L	L	L	L	L	H	H	H	H	L	H	L	L	L	L	L	L	L61
		L	L	L	L	L	L	H	H	H	H	H	L	L	L	L	L	L	L	L62
	Green	L	L	L	L	L	L	H	H	H	H	H	H	L	L	L	L	L	L	Green L63
Gray Scale of Blue	Black	L	L	L	L	L	L	L	L	L	L	L	L	L	L	L	L	L	L	L0
	Dark ↑ ↓	L	L	L	L	L	L	L	L	L	L	L	L	L	L	L	L	L	H	L1
		L	L	L	L	L	L	L	L	L	L	L	L	L	L	L	L	H	L	L2
		:	:	:	:	:	:	:	:	:	:	:	:	:	:	:	:	:	:	L3~L60
		:	:	:	:	:	:	:	:	:	:	:	:	:	:	:	:	:	:	
	Light	L	L	L	L	L	L	L	L	L	L	L	L	H	H	H	H	L	H	L61
		L	L	L	L	L	L	L	L	L	L	L	L	H	H	H	H	H	L	L62
	Blue	L	L	L	L	L	L	L	L	L	L	L	L	H	H	H	H	H	H	Blue L63
Gray Scale of White & Black	Black	L	L	L	L	L	L	L	L	L	L	L	L	L	L	L	L	L	L	L0
	Dark ↑ ↓	L	L	L	L	L	H	L	L	L	L	L	H	L	L	L	L	L	H	L1
		L	L	L	L	H	L	L	L	L	L	H	L	L	L	L	L	H	L	L2
		:	:	:	:	:	:	:	:	:	:	:	:	:	:	:	:	:	:	L3~L60
		:	:	:	:	:	:	:	:	:	:	:	:	:	:	:	:	:	:	
	Light	H	H	H	H	L	H	H	H	H	H	L	H	H	H	H	H	L	H	L61
		H	H	H	H	H	L	H	H	H	H	H	L	H	H	H	H	H	L	L62
	White	H	H	H	H	H	H	H	H	H	H	H	H	H	H	H	H	H	H	White L63